



2014 International Workshop

Affordable Systems Engineering: An Application of Model-Based System Patterns To Consumer Packaged Goods Products, Manufacturing, and Distribution

By

Consumer Packaged Goods Representative

Ways to Achieve a Billion \$ in Sales



1,000,000,000
 100,000,000
 10,000,000
 1,000,000
 100,000
 10,000
 1,000
 100
 10
 1

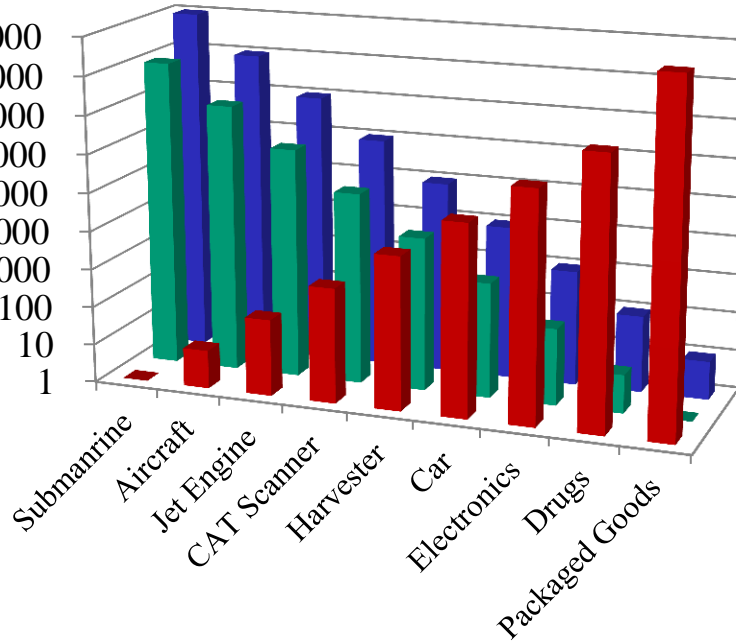

■ Units Sold
 ■ \$ Payroll/Unit
 ■ \$ Price/Unit

Consumer Packaged Goods (CPG)

- Everything is upside down:
 - One engineer for multiple projects vs. concurrent engineering
 - One engineer wearing multiple hats vs. one or more engineers for each discipline
 - Millions of products per day vs. a handful per day/week/month/year
 - Etc., etc.,...

“Turn of the Century”

- Leap to CAx (CAD,CAM, CAE...)
 - Increased productivity of design
 - Led to extensive reuse/reapplication of designs
 - Traditional requirements management scrutinized for being resource intensive
- Six Sigma, 5S, Lean...
 - Increased productivity, but often eliminated the key resources in requirements management

Problem Statement

- Need to re-establish formal requirements management before organizational memory of legacy requirements fades
- Systems Engineering (SE) is an established discipline that we wish to deploy, but...
- Incremental headcount is hard to justify, so SEs will be vastly outnumbered by other engineering disciplines

CPG Requirements of SE

- Fully integrated with CAx/PLM
- Systemic means to ensure that requirements are complete to desired level of detail
- Persistent, traceable and reusable requirements over product and process life cycles

What we want in a Nutshell

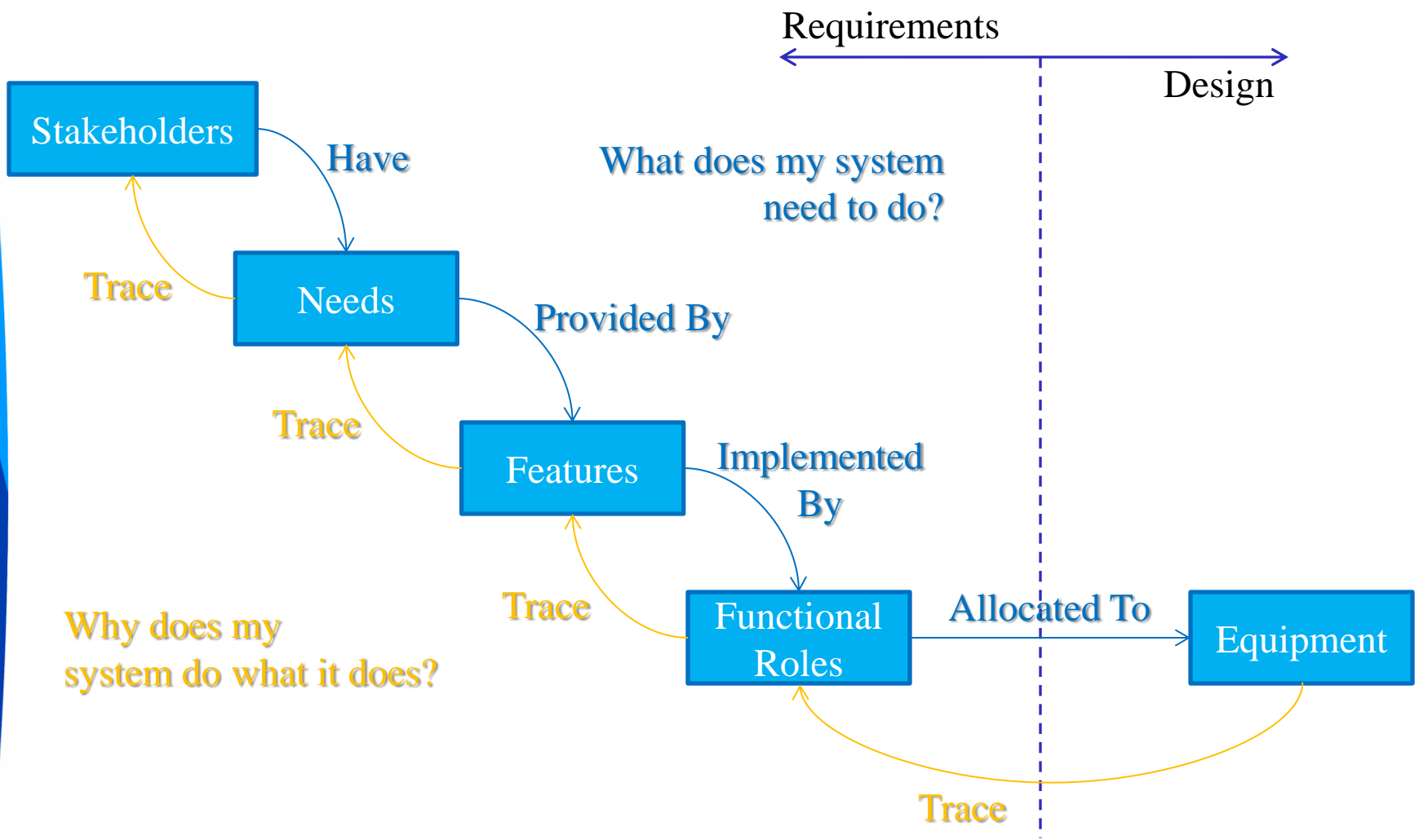

Systematica™ framework for MBSE

- Systematica (S*) Metamodel
 - A succinct model that can describe virtually any system, and that is independent of SE tools or languages used

S* Metamodel

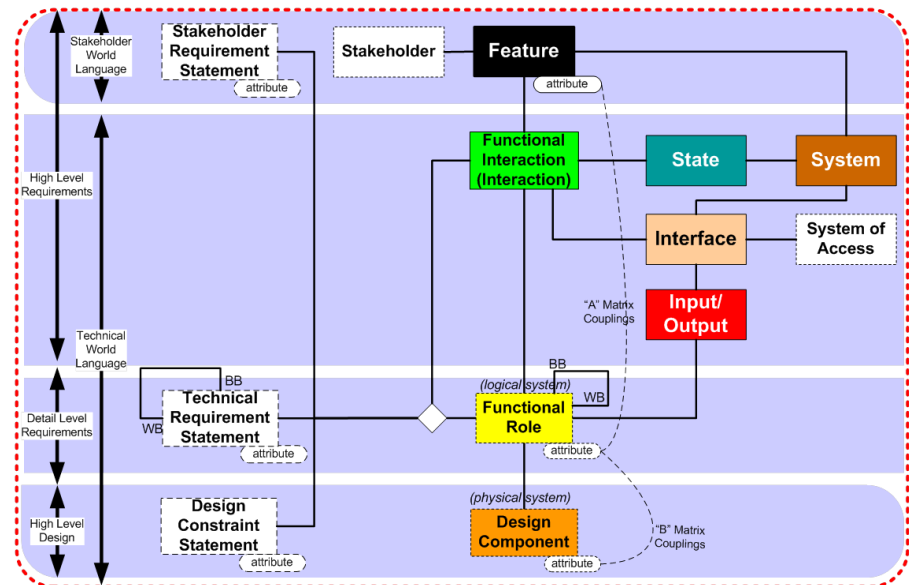

MBSE provides a powerful paradigm for discovering all the Interactions, and therefore all the system Functional and Non-Functional Requirements

Systematica™ Views

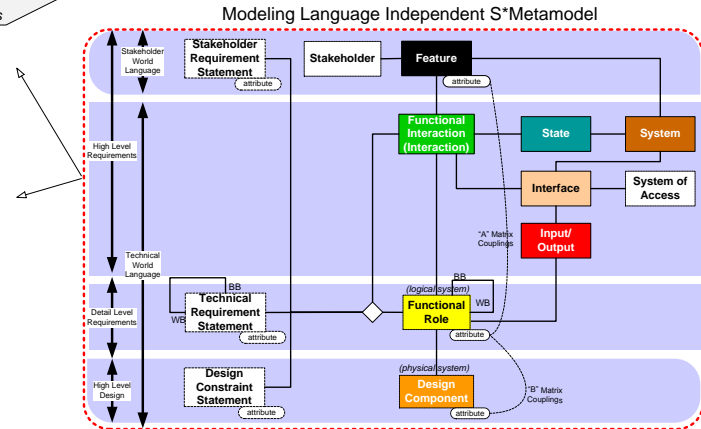
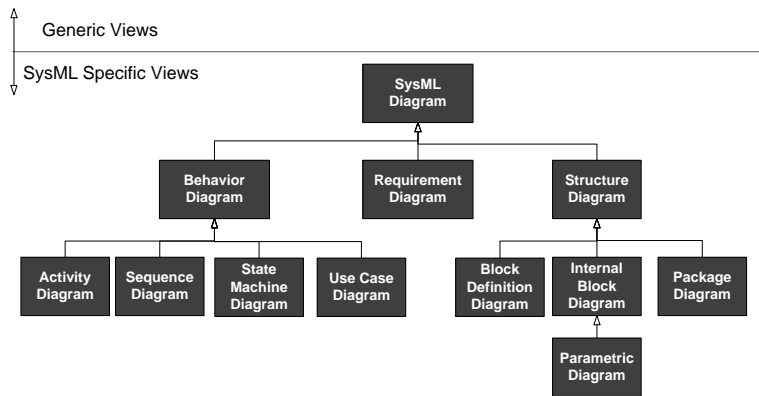
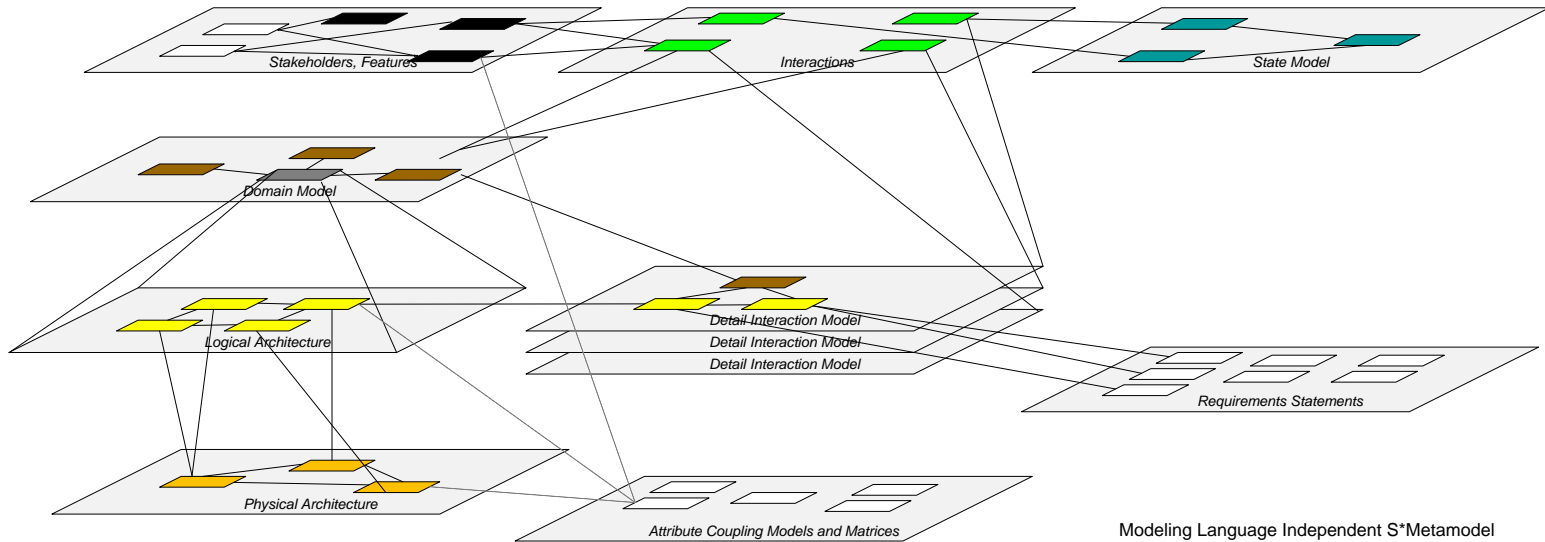

Generic Views

- Models/Diagrams
 - Easy to communicate between system engineers and subject matter experts, e.g., process engineers
 - May include subtle SysML notation that communicates purpose to the process engineer and precise meaning to the systems engineer

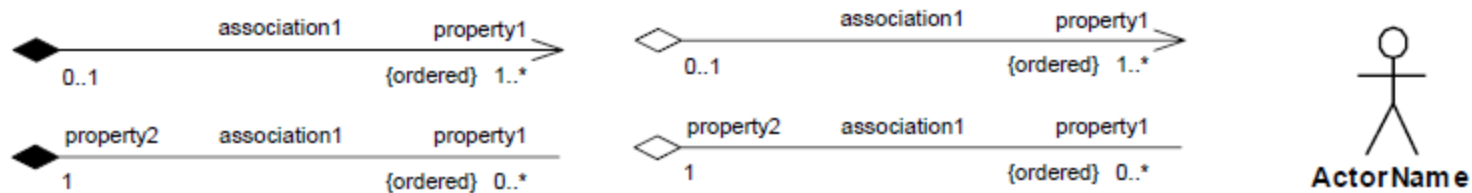

Domain Models

Show the external systems that interact with the Subject System over its domain life cycle.
This defines the System Boundary, External Interfaces and Domain Relationships

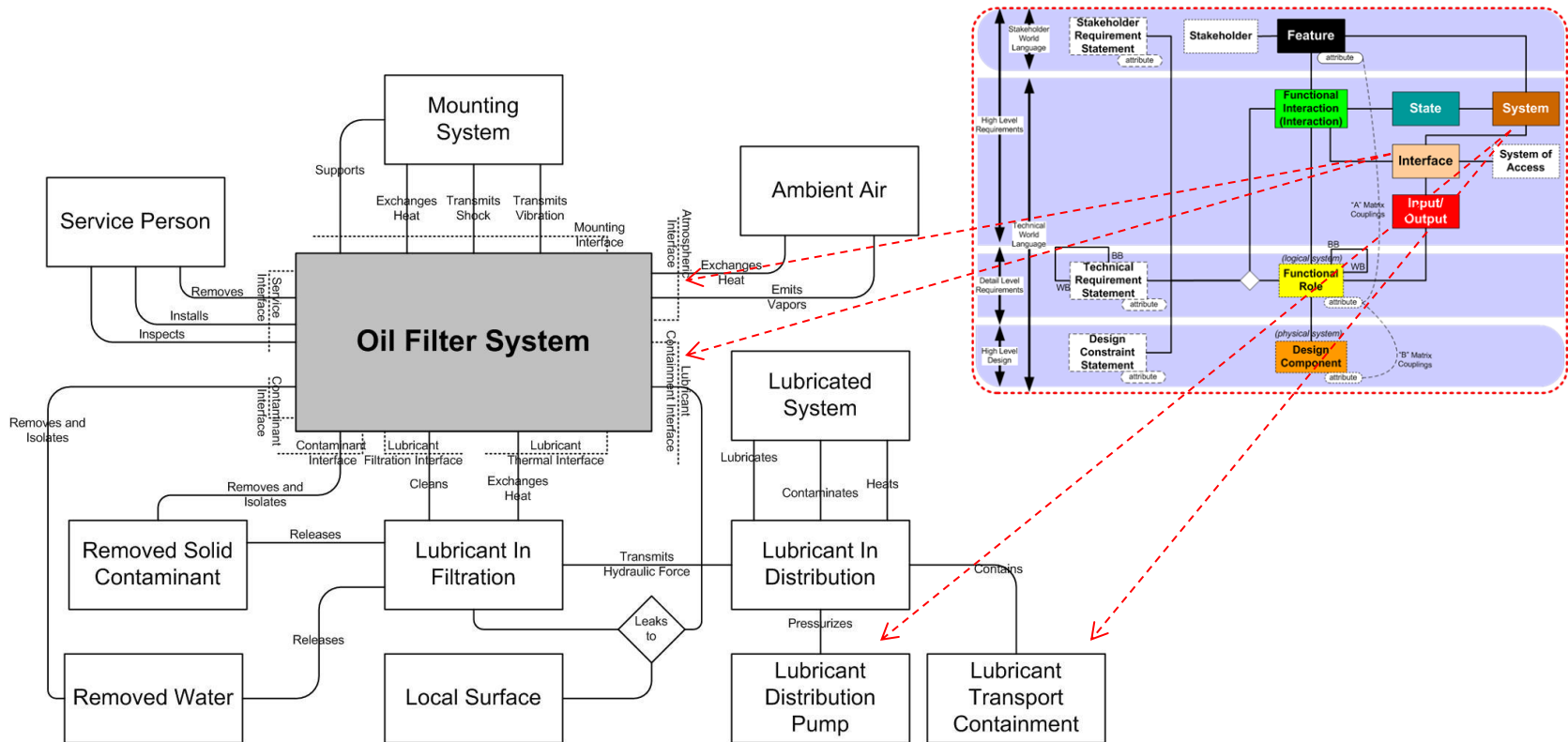

Schindel, W., Peffers, S., Hanson, J., Ahmed, J., Kline, W. "All Innovation Is Innovation of Systems: An Integrated 3-D Model of Innovation Competencies", Proceedings of the 2011 Conference of the American Society for Engineering Education (ASEE)

State Models

State Models directly address a key SE challenge by discovering and describing all Situations, Modes, or Use Cases (environmental states) that a Subject System will encounter. These are associated with functional Interactions that lead directly to requirements.

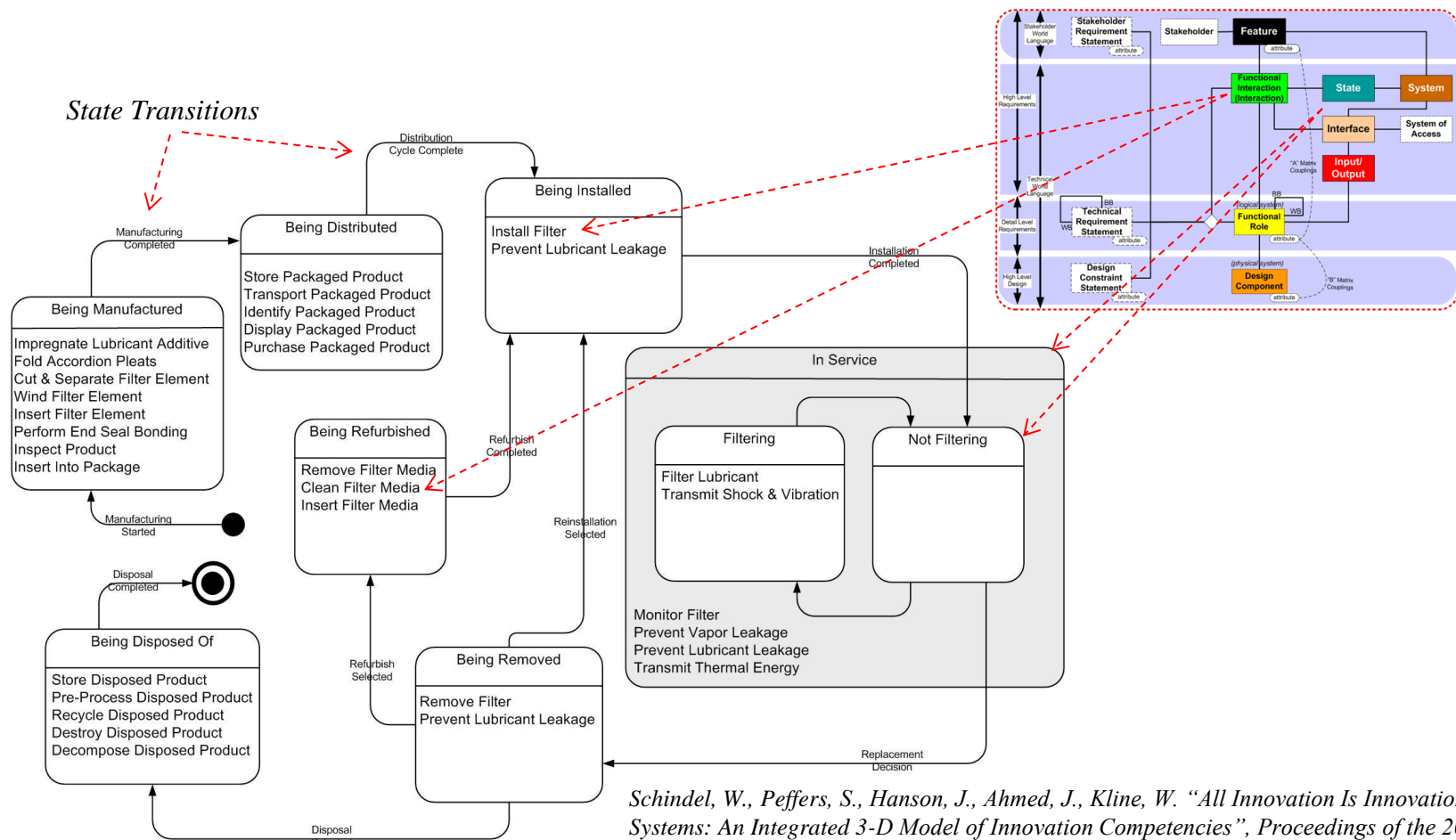

Schindel, W., Peffers, S., Hanson, J., Ahmed, J., Kline, W. "All Innovation Is Innovation of Systems: An Integrated 3-D Model of Innovation Competencies", Proceedings of the 2011 Conference of the American Society for Engineering Education (ASEE)

Logical Architecture Model

Logical Architecture Models directly address key SE challenges by partitioning the structure of requirements into Logical Roles independent of design, then address more SE challenges by stimulating design ideation and role allocation to physical designs and future technologies.

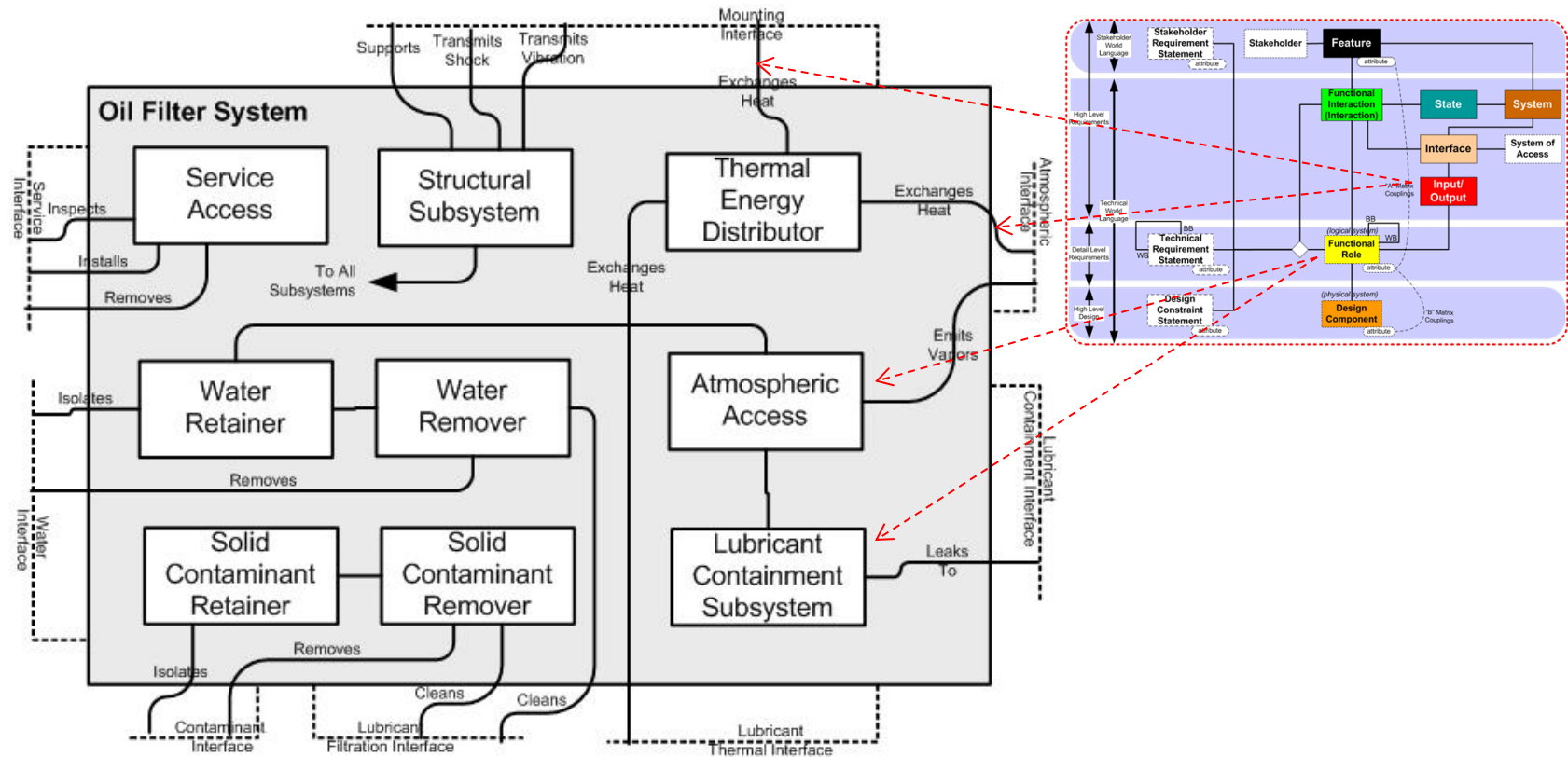

Schindel, W., Peffers, S., Hanson, J., Ahmed, J., Kline, W. "All Innovation Is Innovation of Systems: An Integrated 3-D Model of Innovation Competencies", Proceedings of the 2011 Conference of the American Society for Engineering Education (ASEE)

Feature Model

Feature Name	Feature Definition	Feature Attribute	Attribute Definition	Attribute Values
Environmental Compliance	The conformance of a system to applicable regulations governing impact on the natural environment.	Environmental Risk Issue	The environmental compliance issue(s) that arises due to operation of the system. May be multiply instantiated.	Fiber Discharge, Glycol Discharge, Hot Melt Discharge, Hydraulic Fluid Discharge, Noise Pollution, Odor, Process Air Discharge
Feature Module Fault Management	The capability of a system to manage, or to have externally managed, the prevention and life cycle of system faults.	Manageability Level--FM	The type of management capability of this system, including internal and external local loop management, as well as ability to be managed by high level control systems. More than one instance may be created.	Internal Local Fault Management, External Local Fault Management, Line Level Fault Manageable
Feature Module Security Management	The capability of a system to manage, or to have externally managed, physical and electronic access so that it can be secure from threats to manufacturing system assets and services.	Manageability Level--SM	The type of management capability of this system, including internal and external local loop management, as well as ability to be managed by high level control systems. More than one instance may be created.	Internal Local Security Management, External Local Security Management, Line Level Security Manageable
Health and Safety	The ability of the system to be installed, operated, maintained, and otherwise managed over its life cycle, in a fashion conforming to the guidelines as to the health and safety of those who operate, use, live nearby, or otherwise interact with it.	Health and Safety Risk Issue	The type of general hazard(s) presented by the system, which need to be mitigated.	Electric Shock, Environmental Vibration, E-Stop, Fire, Fork Lift Traffic Isolation, Human Traffic Isolation
Utilities and Space Compatibility	The ability of the system to acceptably perform while consuming utilities of a given availability, quality, and amount, while occupying allocated physical plant space and in the airspace conditions available.	Resource Type	The type of utility, space, or other resource with which the system must be compatible. More than one instance may be created.	120AC, 220AC, 480AC, AGM Delivery, Central Vacuum, Compressed Air, Cooling, CS10, Fiber, Glycol, Heat, High Vacuum, Hot Melt, Hydraulic Power, Process Air, Space
Transformation Capability	The capability to carry out a single manufacturing process transformation of the structural, chemical, or other physical aspects of work-in-process materials, into an intermediate or final manufactured configuration.	Transformation Type	The type of transformation that is performed. More than one type may be instantiated for a single system.	Apply Glue Combine Web Material Delivery Splice Material Buffer Web

Feature Models make explicit the ultimate stakeholder outcomes against which all decisions, trade-offs, optimizations, and outcomes will be scored and selected.

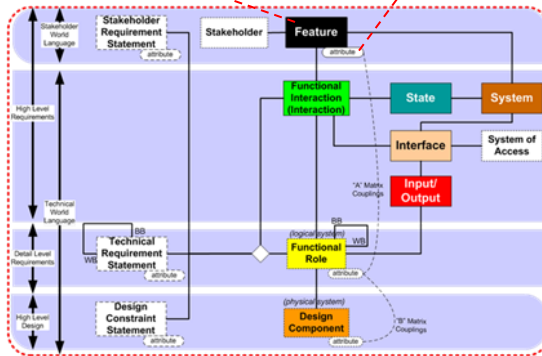

Requirement Statements In Transfer Function Form

Every requirements statement should tell us something about system Inputs, Outputs, how they are Related, and possible Attributes (parameterization) of that relationship:

- Not every requirements statement needs to contain all of these.
- But, every statement should contain some of them.
- And the aggregation of these statements should form an “equation” characterizing the overall I/O relationship—or we are not done.

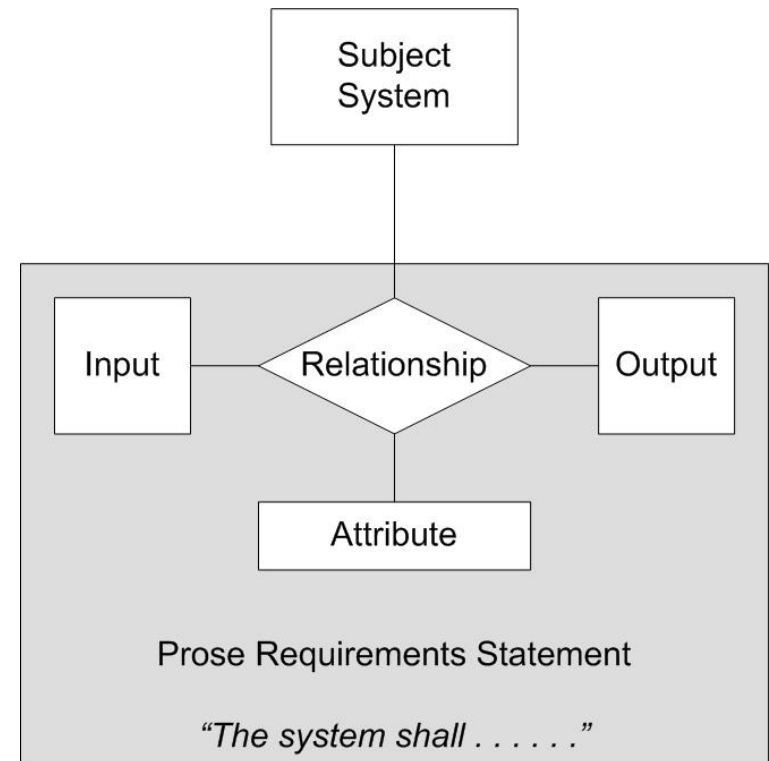

Schindel, W., "Requirements Statements Are Transfer Functions: An Insight from Model-Based Systems Engineering", INCOSE 2005

Example Requirements Statements in I/O form

1. “The Lawnmower System shall *operate* with [Hourly Mowing Capacity] of at least 1 level ground acre per hour, at [Max Elevation] up to 5,000 feet above sea level, and [Max Ambient Temperature] of up to 85 degrees F., at up to 50% [Max Relative Humidity], for [Foliage Cutting Capacity] of Acme American Standard one week Lawn Grass.”
2. “The Lawnmower System shall *operate* using Fuel consisting of gasoline having a [Min Octane Rating] of not less than 92, combusted with Atmospheric Air.”
3. “The Lawnmower System shall *operate* with [Fuel Economy] of at least 1 hour / gallon at [Min Elevation] of 0 feet ASL, at [Max Ambient Temperature] 85 degrees F., 50% [Max Relative Humidity], for Acme American Standard one week Lawn Grass.”

To make the above clear:

- Inputs and Outputs are underlined.
 - [Attributes] are in brackets.
 - *Relationships* are italicized.
- Just for this example—not required.

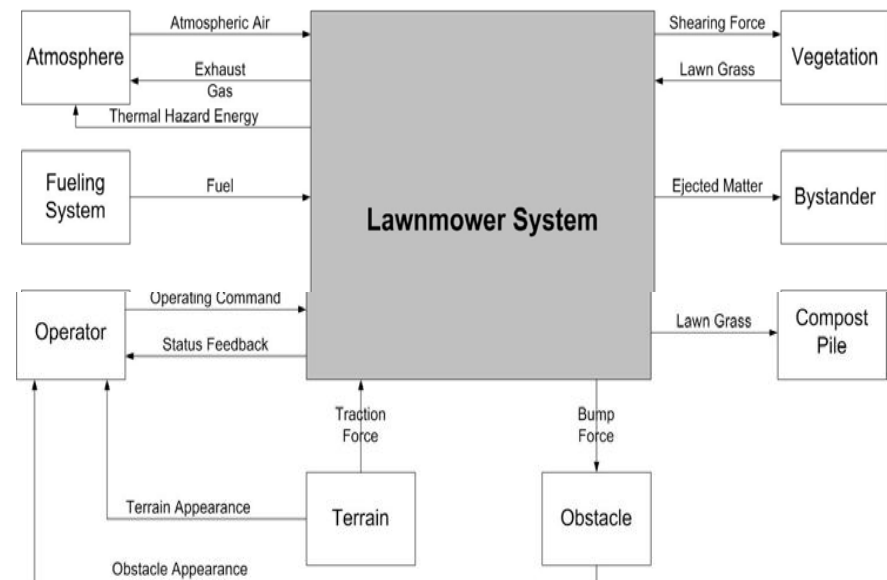

Convenience of Parameterized Requirements Statements

Attribute	Units	Design 1	Design 2	Design 3
Hourly Mowing Capacity	Level ground acres per hour	1.5	1.75	2
Max Elevation	Feet above sea level	6,000	7000	10,000
Max Ambient Temperature	Degrees F	80	90	100
Min Octane Rating	Octane	92	92	92
Fuel Economy	Hours / Gallon	2	1.75	2
Min Elevation	Feet ASL	0	0	0
Max Relative Humidity	%	50	50	50

- The requirements statement remain unchanged as changes in attribute values are tracked separately over product life-cycle

Bringing it all together

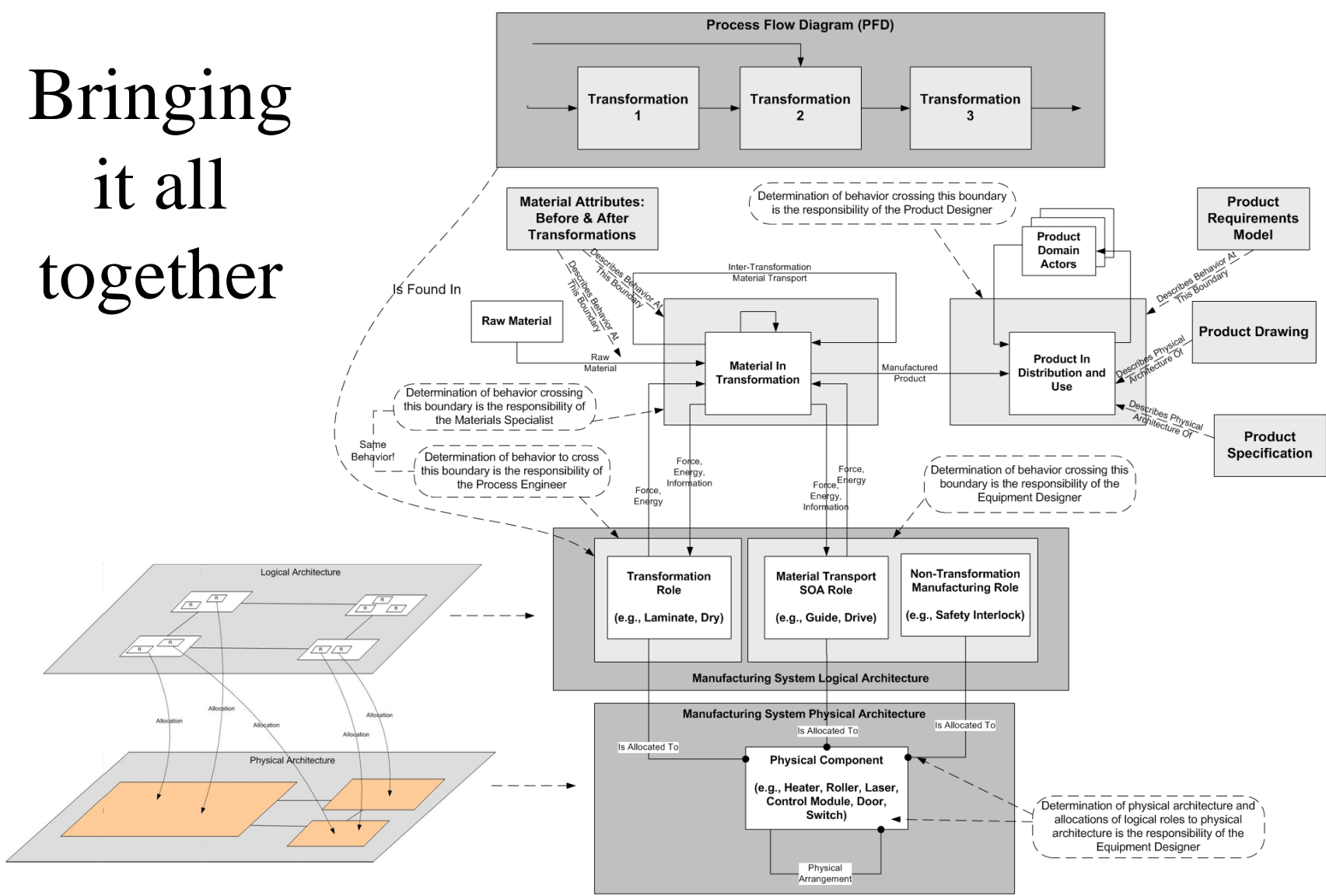

Logical and Physical Architecture, Cross-Domain Development & Engineering Roles

Schindel, W. "Integrating Materials, Process & Product Portfolios: Lessons from Pattern-Based Systems Engineering", *Proc. of 2012 Conf. of Soc. for the Advancement of Material and Process Engineering*, Baltimore, MD., 2012.

Reusability

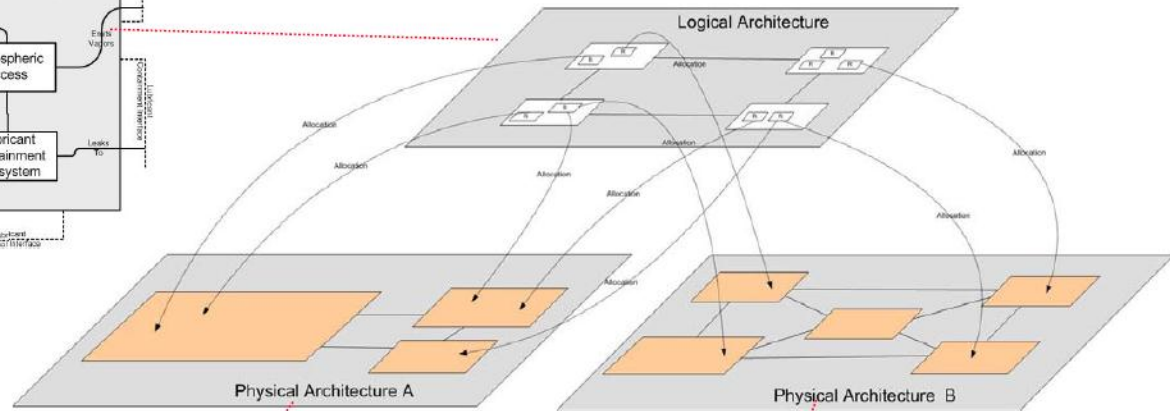
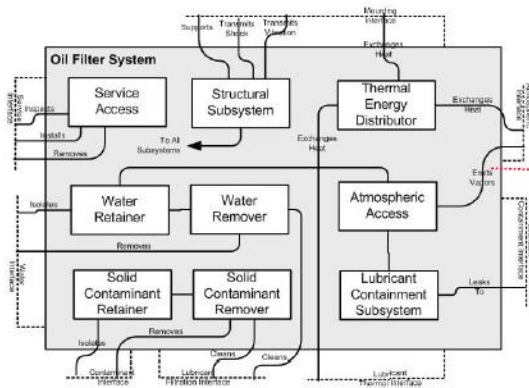

- A single logical architecture can support many physical architectures
- A change in one or more attribute values produces a different system

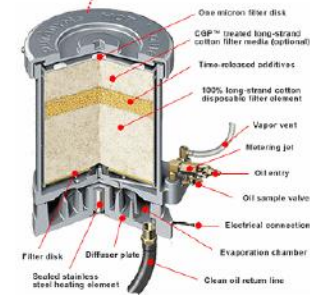
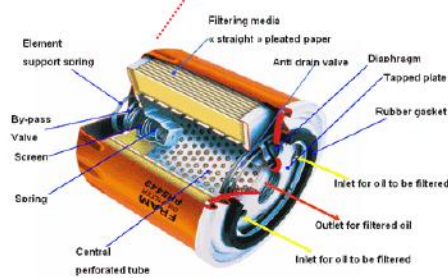

Schindel, W., Peffers, S., Hanson, J., Ahmed, J., Kline, W. "All Innovation Is Innovation of Systems: An Integrated 3-D Model of Innovation Competencies", Proceedings of the 2011 Conference of the American Society for Engineering Education (ASEE)

Extending MBSE to PBSE

- Re-usable, configurable models (patterns)
 - Moves the human adoption challenge from “learning how to model” to “learning our enterprise’s models”

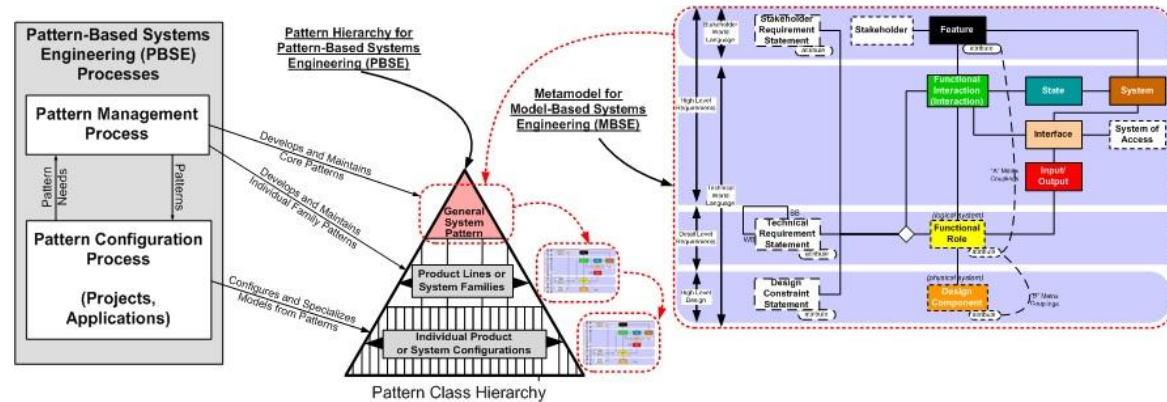

Transition to PBSE

- MBSE = 1 Off
- PBSE = One to Many

2012 Chevrolet Car Corvette		STANDARD EQUIPMENT - Coupe and Convertible								
Free Flow RPO Code	Ref. Only RPO Code	Description	Coupe 1Y167				Convertible 1Y167			
			1LT	2LT	3LT	4LT	1LT	2LT	3LT	4LT
	UJM	Tire Pressure Monitor System, air pressure sensors in each tire with pressure display in Driver Information Center	S	S	S	S	S	S	S	S
		Trunk release, push button open	--	--	--	--	S	S	S	S
		Visors, driver and front passenger illuminated vanity mirrors	S	S	S	S	S	S	S	S
		Windows, power with driver and passenger Express-Down	S	S	S	S	S	S	S	S
		Antenna, integral, hidden	S	S	S	S	S	S	S	S
	CD5	Convertible top, manual folding, includes glass rear window with integral defogger	--	--	--	--	S	S	--	--
	CM7	Convertible top, power folding, includes glass rear window with integral defogger	--	--	--	--	--	S	S	
		Daytime Running Lamps	S	S	S	S	S	S	S	S

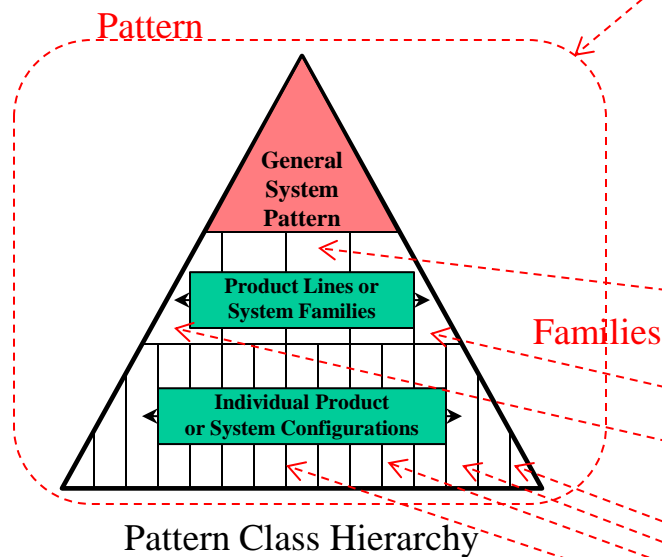

Configurations

CHEVROLET		
2012 Model Year Data as of Jan 3, 2012		
Coupe 25%	Grand Sport Coupe 44%	Z06 4%
1LT 53%	1LT 14%	1LZ 9%
2LT 19%	2LT 15%	2LZ 22%
3LT 26%	3LT 63%	3LZ 69%
4LT 2%	4LT 8%	
Convertible 6%	Grand Sport Convertible 19%	ZR1 3%
1LT 45%	1LT 3%	1ZR 5%
2LT 11%	2LT 9%	3ZR 95%
3LT 40%	3LT 70%	
4LT 4%	4LT 18%	

Summary of Approach

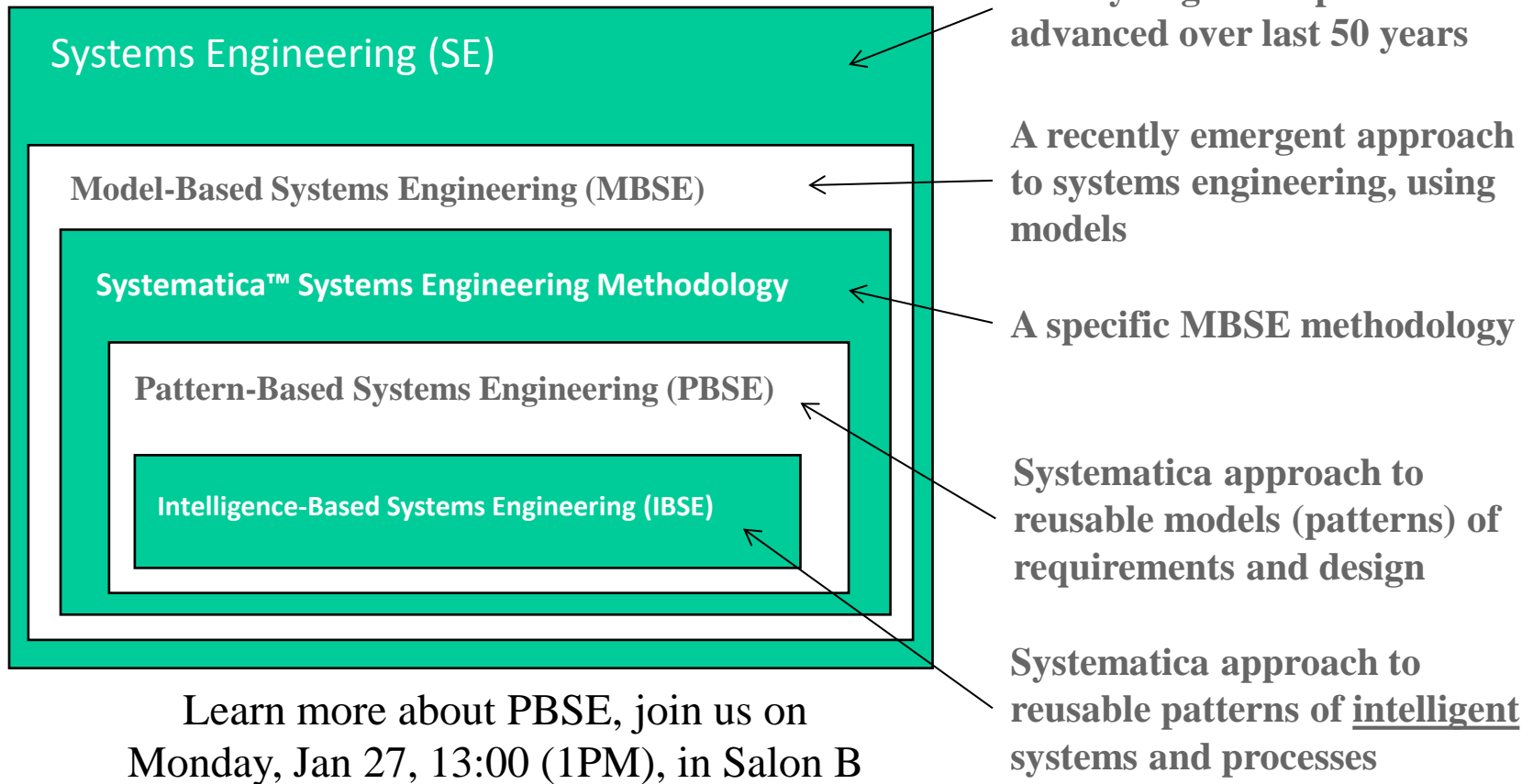

Learn more about PBSE, join us on
Monday, Jan 27, 13:00 (1PM), in Salon B

Infusing MBSE Across the Enterprise

- Some observations and experiences to date:
 - Lost organizational capability generally can't be restored, it must be re-invented (SE)
 - Can't sell SE based on money we will save in the long term
 - How will you save money on the very next design?
 - Make a little, sell a little
 - It is a journey, not an event
 - Critical mass is achieved with integration into PLM

Conclusion

- MBSE and PBSE make Systems Engineering an attainable goal for CPG
 - We are re-inventing lost organizational capability
 - New capability is superior, pervasive and persistent compared to requirements management before SE
 - Fully integrated solution can initially be supported by contract Systems Engineers
 - Demonstrated value will allow us to add dedicated Systems Engineers to our own organization
 - S* Methodology independent of SE Tools, we have ported it to DOORS, TcUA and soon: Enovia

Questions

Pattern-Based Systems Engineering (PBSE)

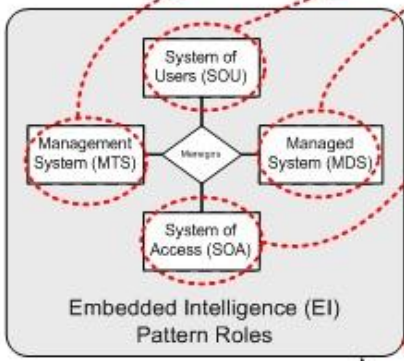
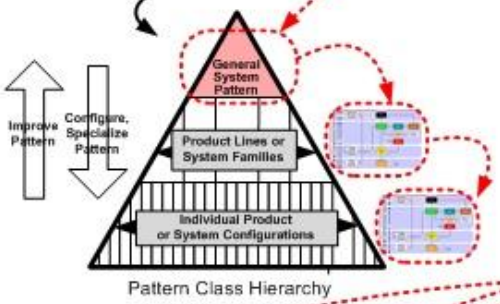

Intelligence-Based Systems Engineering (IBSE)

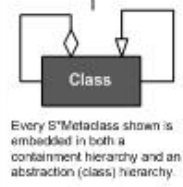
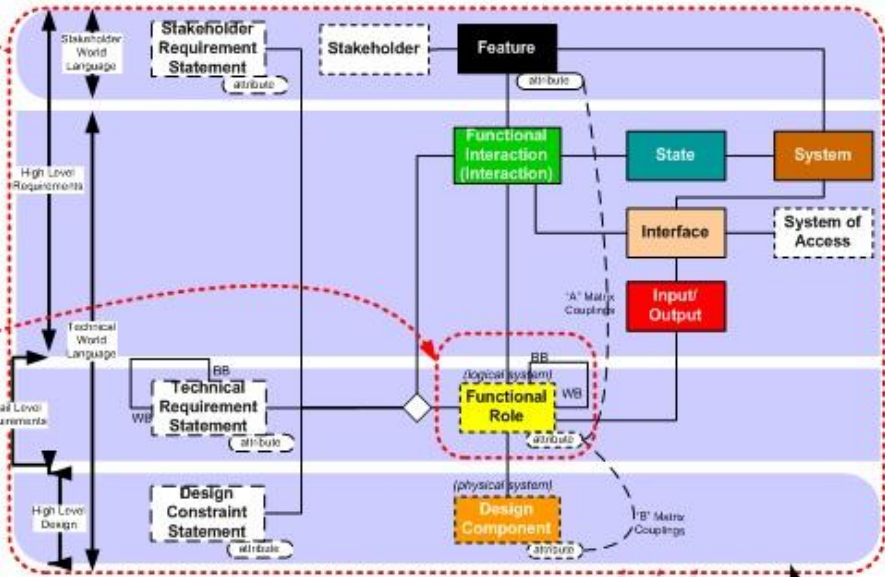
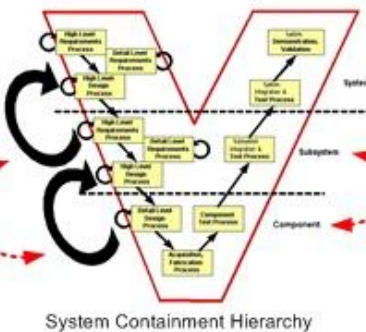
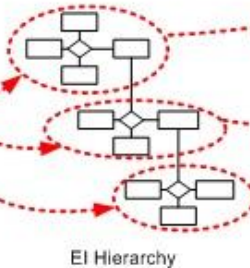

S* Metamodel for Model-Based Systems Engineering (MBSE)