



Model-based Systems Engineering Telescope Modelling Challenge Team

Robert Karban
30 January 2011



City of Phoenix



MBSE Telescope Modeling Challenge Team



About Robert





Agenda

- Challenge team for Telescope Modeling
 - About
 - Achievements
- Early adopters at the European Southern Observatory
 - About ESO
 - The European Extremely Large Telescope (E-ELT) Project
 - Modeling in the E-ELT project
 - Status
- Live Demo of the Models



Challenge team for Telescope Modeling





About SE²

- Collaboration between European Southern Observatory (ESO) and German Chapter of INCOSE (GfSE) since 2007
- Access to high-tech project, the Active Phasing Experiment (APE).
- The team members are:
 - Robert Karban (ESO)
 - Tim Weilkiens (oose GmbH)
 - Rudolf Hauber (HOOD Group)
 - Rainer Diekmann
 - Michele Zamparelli (ESO)
 - Andreas Hein (TU Munich)
- Former members: Andreas Peukert (TU Munich)



What is the challenge project about?



- System case study
 - APE technology demonstrator for future Extremely Large Telescope (ELT)
 - High-Tech interdisciplinary opto-mechatrical system in operation at Paranal observatory
- Goals
 - Create modeling guidelines and conventions for all system aspects, hierarchy levels, and views
 - Create fully fledged SysML model
 - Documented at <http://mbse.gfse.de>

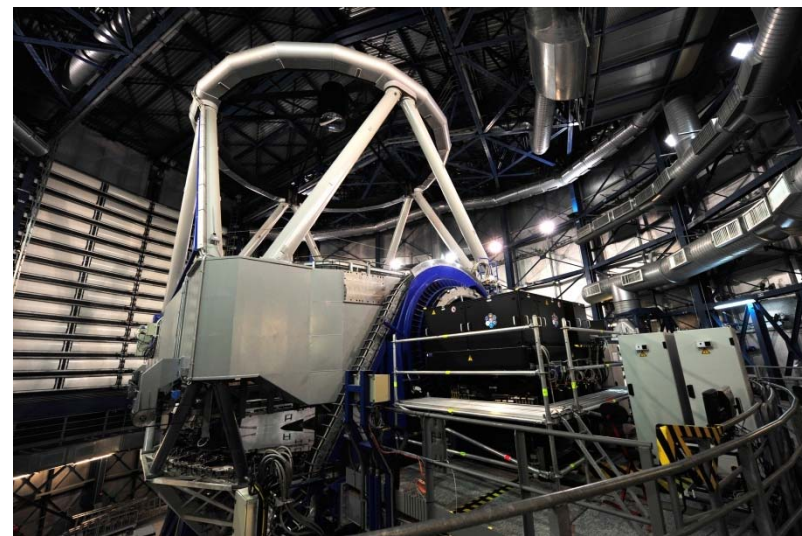



MBSE Telescope Modeling Challenge Team

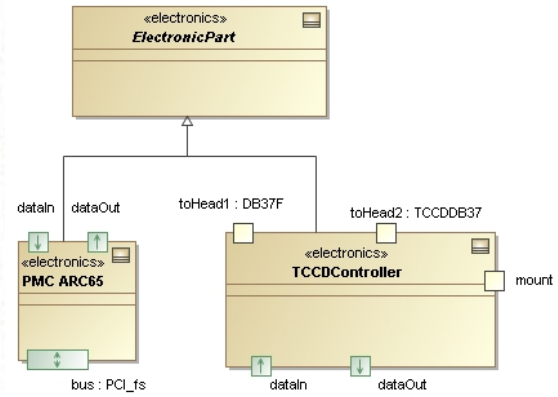
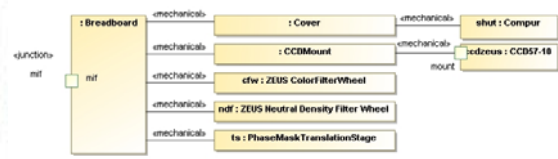
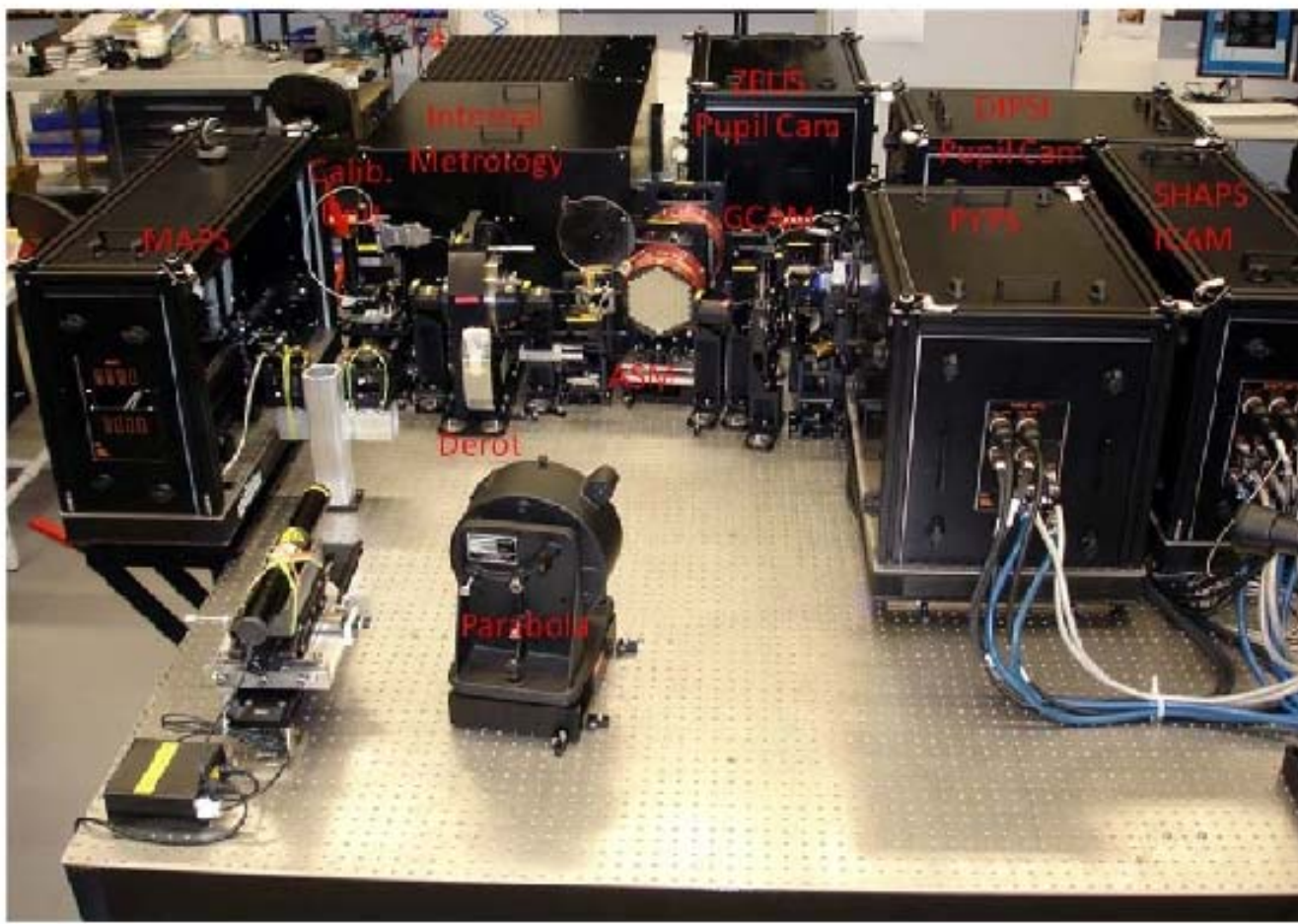



MBSE Telescope Modeling Challenge Team

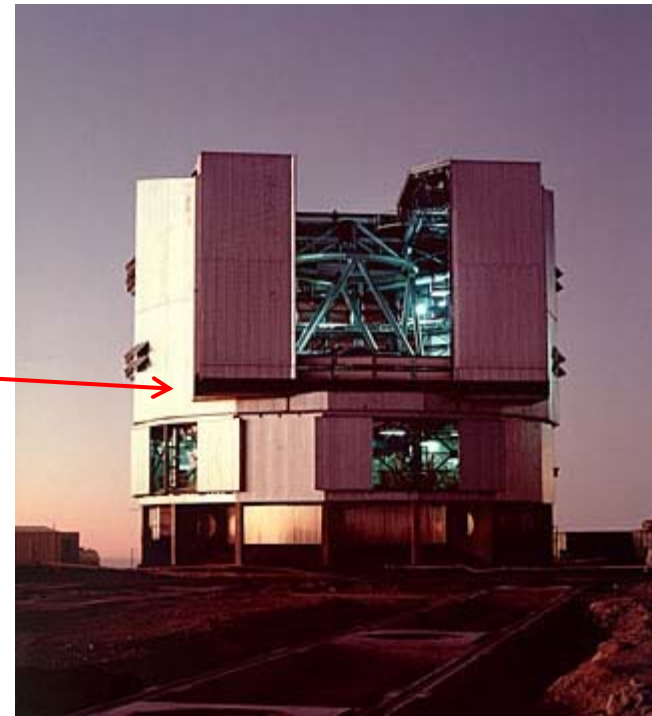
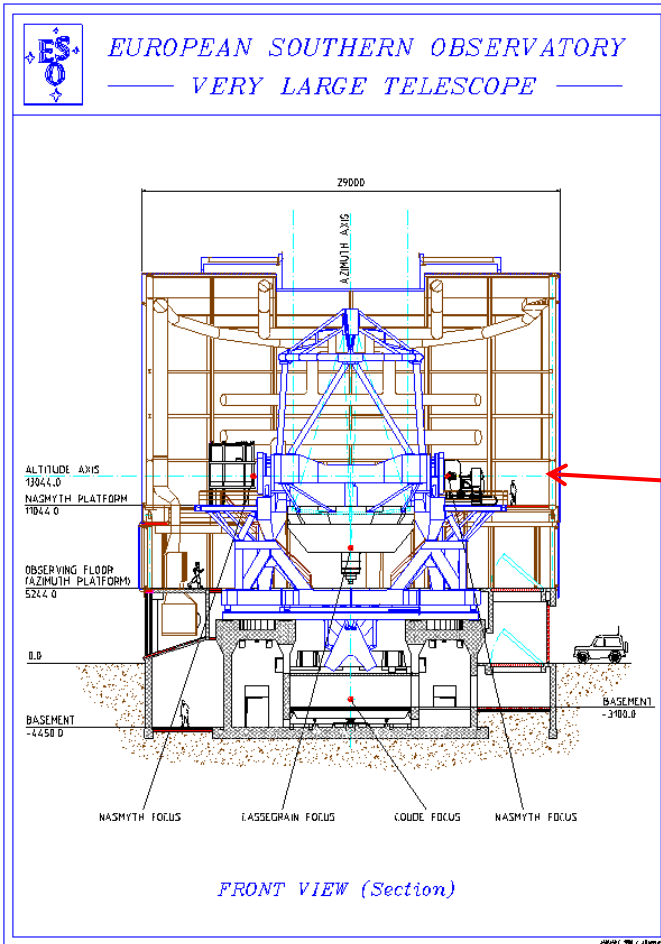

APE was installed at telescope in Atacama desert, Chile.



Images on this slide were produced by ESO City of Phoenix



What have we achieved?

- APE model, guidelines and best practices:
 - Model Organization
 - Style, Layout Naming Conventions
 - System Views
 - Requirements and Use Case Modeling
 - Structure, Interface, and Behavior Modeling
 - Non-functional Aspects Ontologies, Part Catalogs
 - Variant Modeling
 - Integration with other Disciplines
 - Cross-cutting the model and Traceability
 - Domain Specific Model Extensions
- Model, Model library and SE Profile
- Plug-in for modeling tool
- Input for tool vendor and SysML RTF

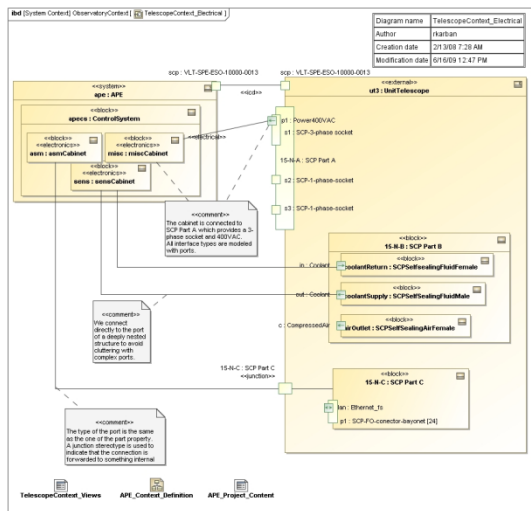

Cookbook for MBSE with SysML



MBSE Telescope Modeling Challenge Team



Early Adopters at ESO



City of Phoenix



ESO

Non-profit Intergovernmental European Organisation for Astronomical Research in the Southern Hemisphere

<http://www.eso.org>

Headquarters in Munich, Germany, 3 Observatories in Chile

Mission statement

Build and operate world class ground based astronomical facilities



ESO's sites

- Paranal (2600 m)
- La Silla (2400 m)
- Chajnantor (5000 m)

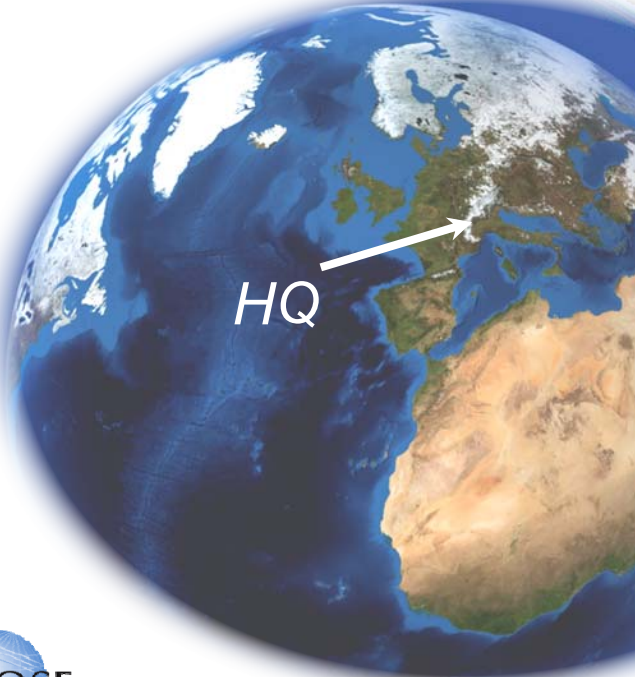



ESO major projects

Very Large Telescope (VLT)
Started 1988, in operation since
1999



Atacama Large Millimeter Array
(ALMA)
Europe-US-Japan
Started 1998, installation starting
now

Images on this slide were produced by ESO
City of Phoenix



What we want to have: The E-ELT

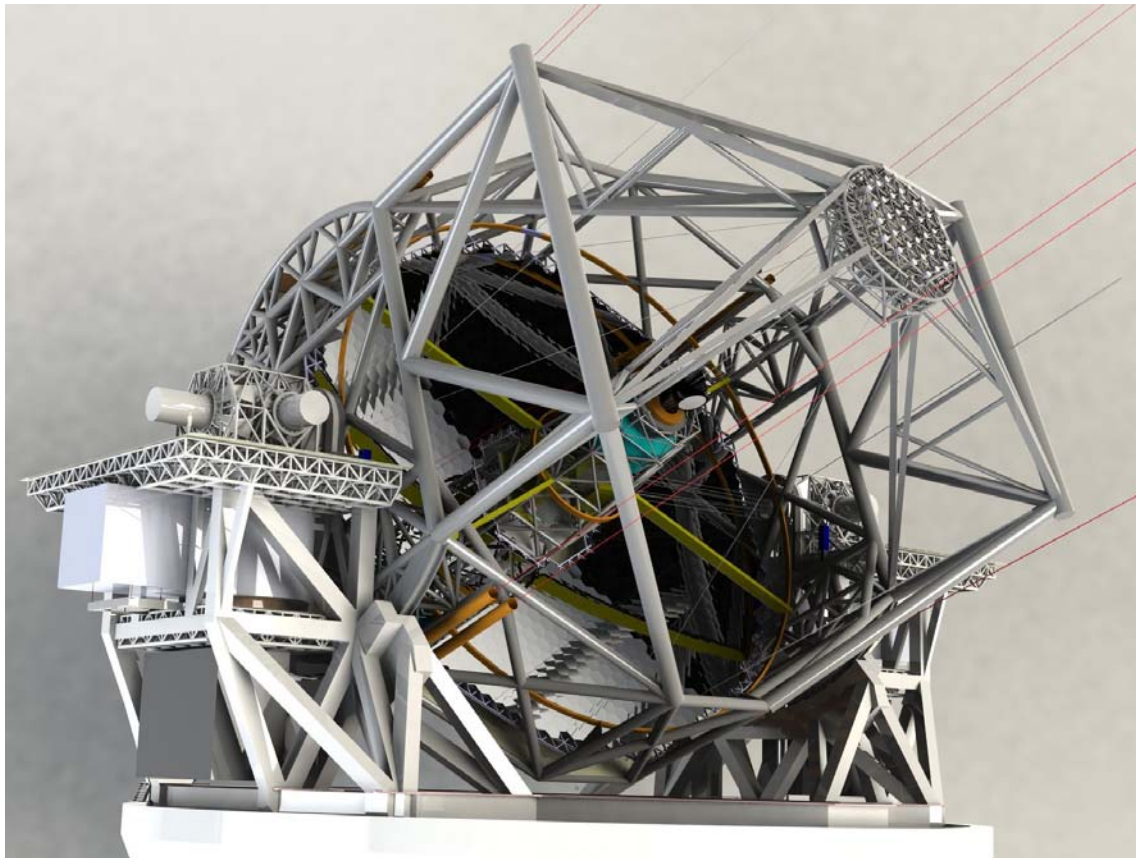

- With its 42 m diameter mirror, the E-ELT will be the largest optical/near-infrared telescope in the world: “the biggest eye on the sky”.
- E-ELT will gather 15 times more light than any other telescope today.
- Exciting science: extra solar planets and discs, galaxy formation, dark energy/dark matter, and frontiers of physics.
- If approved construction could start in 2012 with beginning of operations 2020-2022



MBSE Telescope Modeling Challenge Team

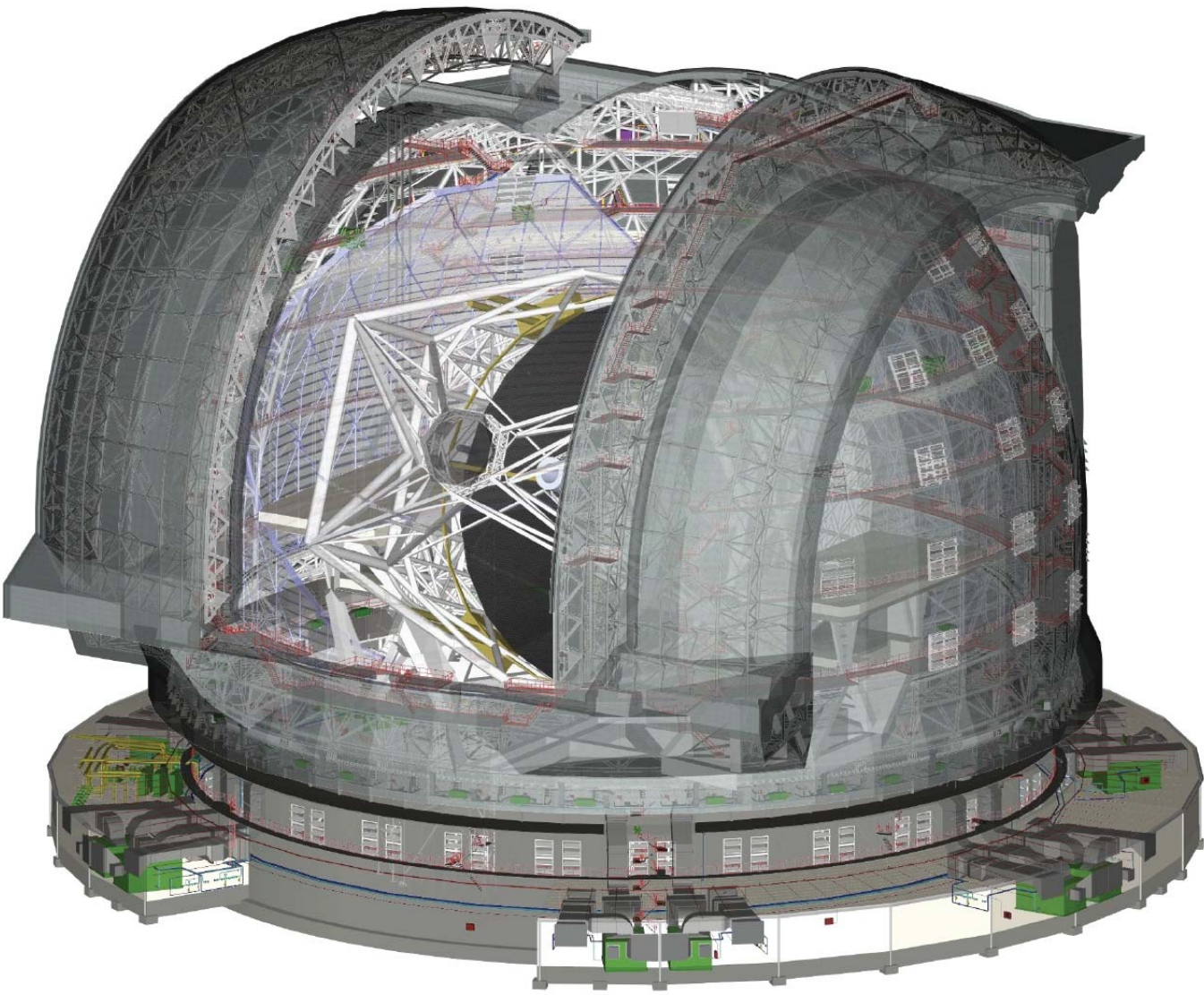



MBSE Telescope Modeling Challenge Team



1 NODAL SOLUTION
 STEP=1
 SUB =13
 FREQ=6.149
 USUM (AVG)
 RSYS=0
 DMX =.001751
 SMN =.121E-05
 SMX =.001751

ANSYS
 SEP 17 2010
 14:56:21
 PLOT NO. 1

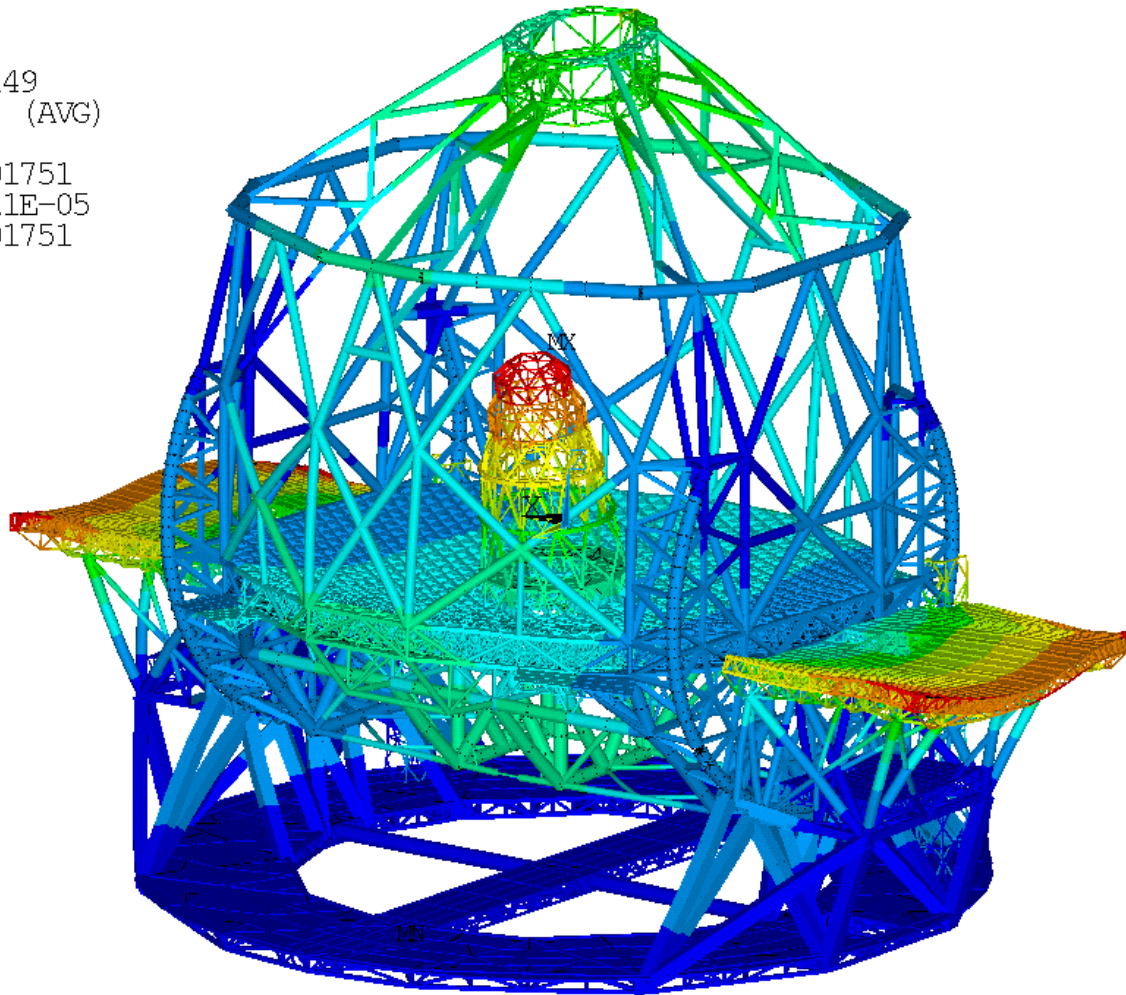

EELT_EAI_0





E-ELT TCS (M1)

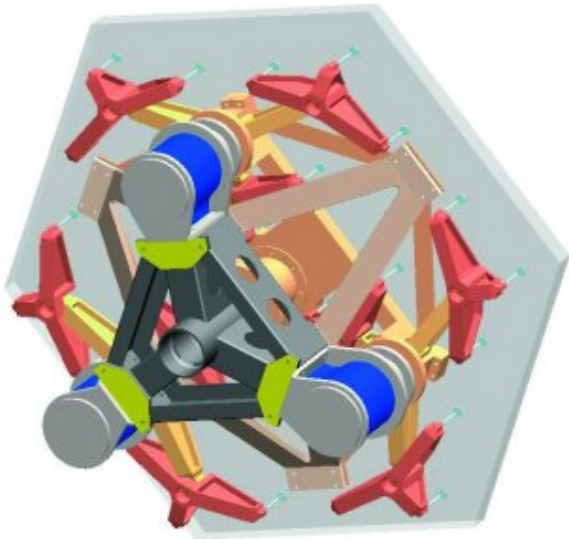

- The position of the 1000 mirrors must be coordinated to deliver a continuous surface with an error below 50nm across the 42m.
- 3000 actuators and 6000 sensors must work in a 1Khz closed loop to meet this requirement.
- Moreover 12000 actuators (12 motors per segment, the warping harness) are responsible for deforming each individual segment in order to correct aberrations
- The control strategy must be flexible and adaptable to e.g. failure of sensors



MBSE Telescope Modeling Challenge Team



Year 1 - Month 1 - Week 1 - Day 3

M1 Evolution

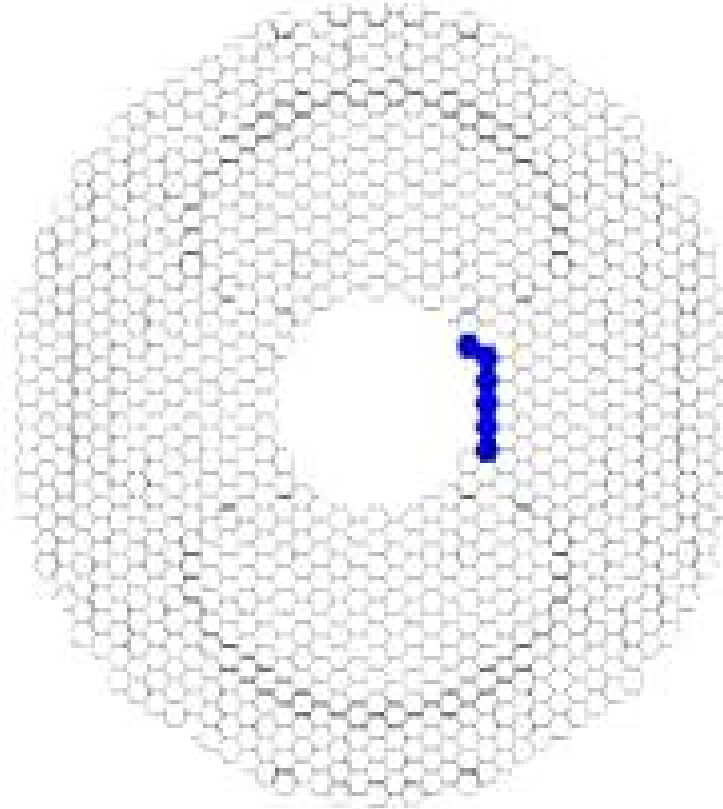

 Not Phased	6	 Missing	0	 Not Usable	0	Mean Age	0
 OK	0	 Too Old	0	 Broken	0	Max Age	0





MBSE Telescope Modeling Challenge Team

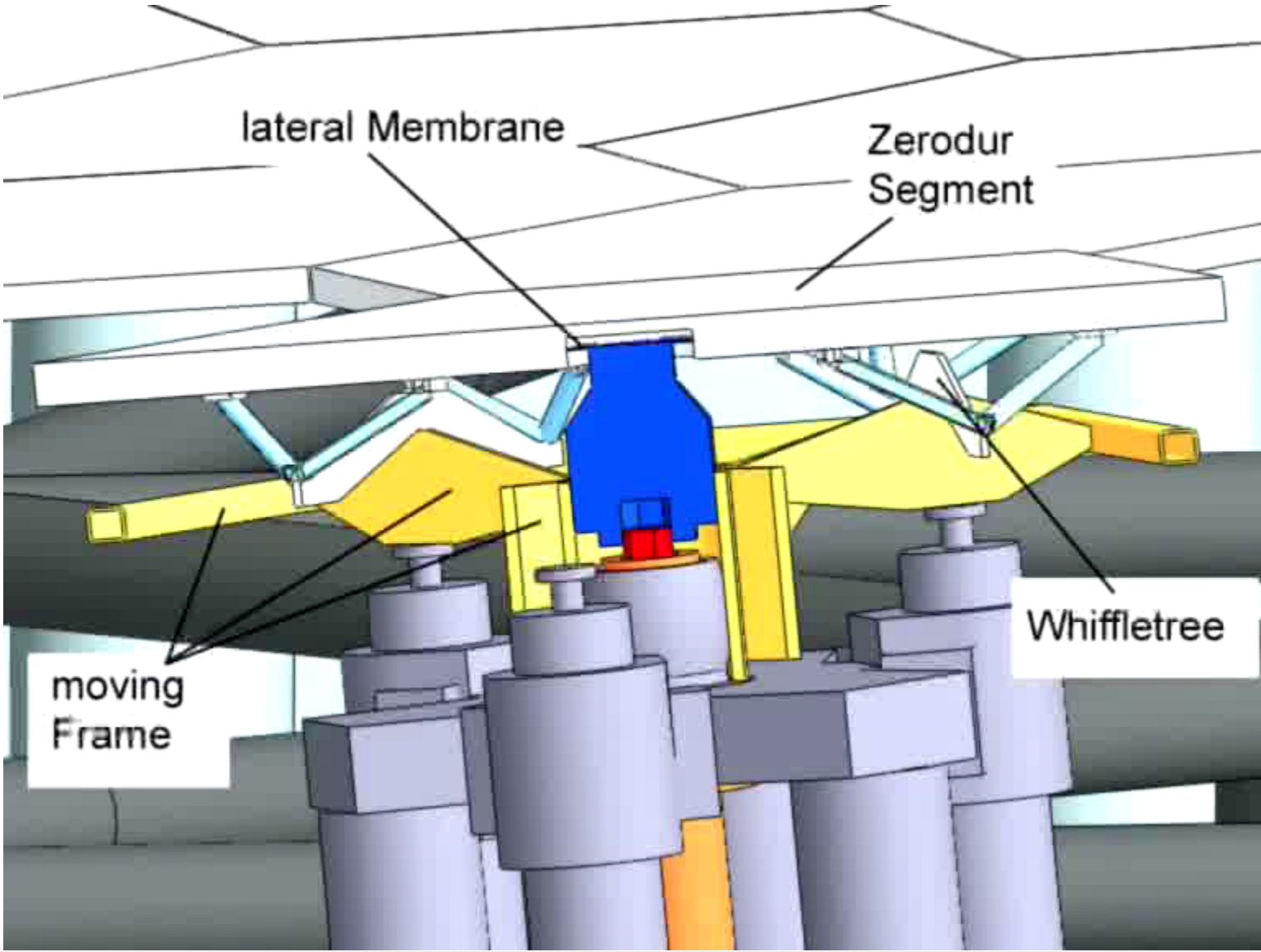



Models, Models, Models

- Static and dynamic performance
 - The FE-model consists of about 19000 nodes and 38000 elements (beam, shell, mass and link).
 - Load cases analysed: gravity, buckling, wind, thermal gradients, earthquake

- Static Behavior under Wind-load
 - Wind Load on FE-model at different angles of elevation for maximum operational wind-speed

- Static Behavior under Thermal loads
 - Temperature Distribution [°C] with a gradient along Z of 0.1°C/m
 - Reference temperature is 20°C

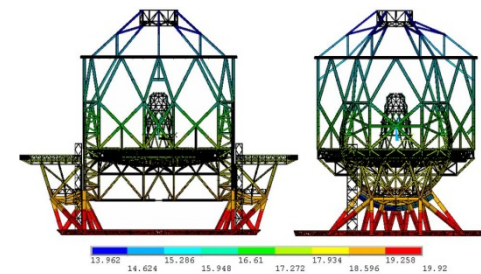
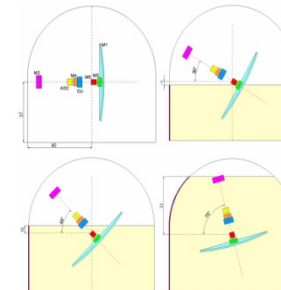
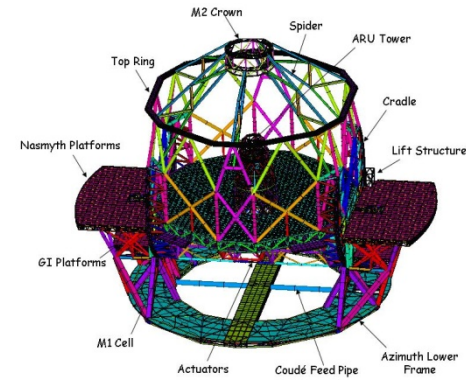



More Models

- Air Conditioning Performance
 - Analyze Wind Buffeting and Dome Seeing
 - Analyse Air Velocity
 - CFD Analysis Models
 - Wind tunnel tests
 - Thermal Analysis Models
- Earthquake Analysis
 - Verify the structural behaviour during an earthquake
 - Analyze time history to obtain stresses and deflections.
- Fire Analysis
 - Determine Smoke-free layer

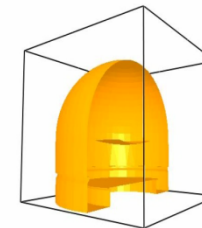
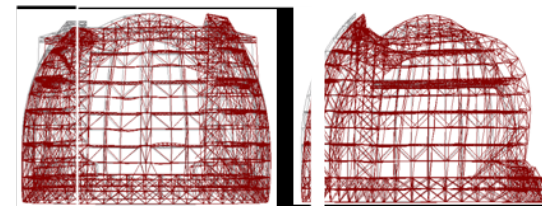
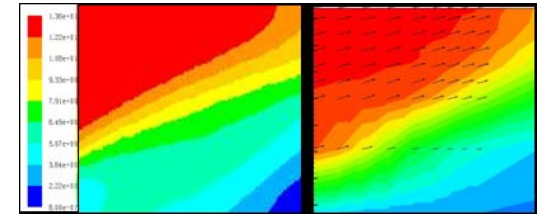
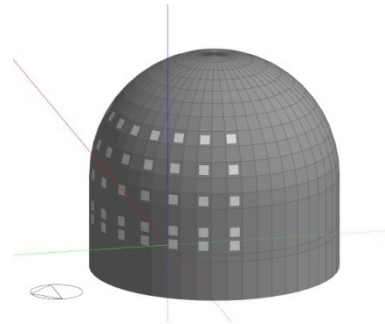

Frame: 0
Time: 0.0



Need more Models?

- Earthquake
 - Analyze displacement of actuators
- FDIR
 - Analyze impact of broken sensors
- Tradeoff analyses
 - Control Structure
 - Drive and sensor location

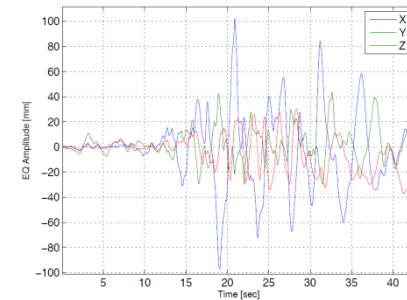

Mirror shape after 25.0 s with ES 239 failure

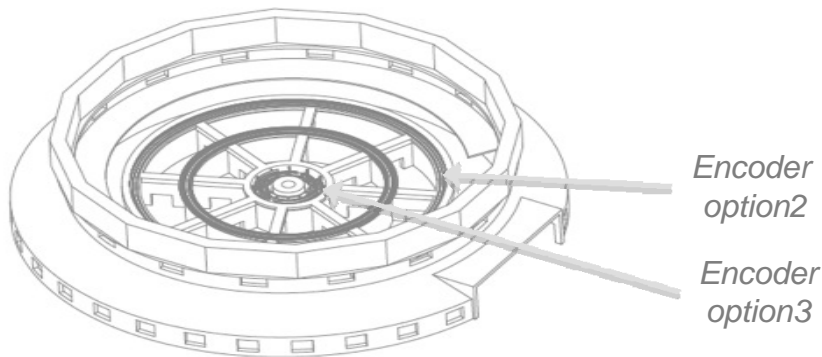
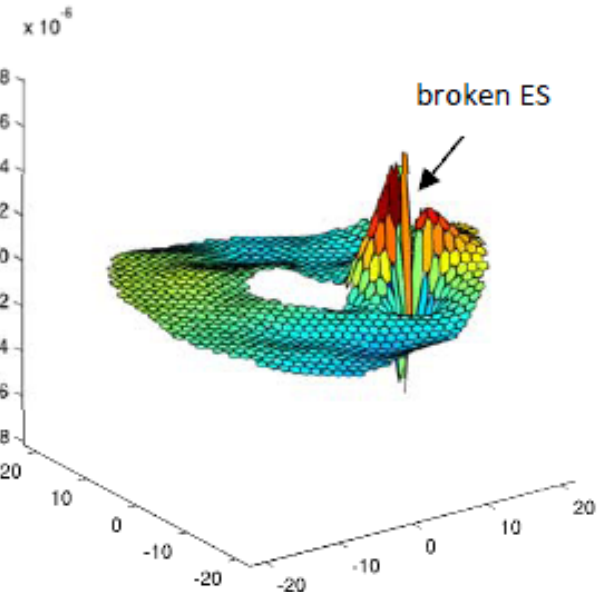



And more Models

- Control strategy
 - Blind tracking
 - Low order optimization, stroke management
 - Numerical DM/WFS registration
 - AO controller
 - 500Hz, 2ms delay
 - Saturation management, anti wind-up
- Control engineering
 - Design trade-off analyses
 - Performance analysis
 - Requirements elicitation for actuators, sensors and control system
 - Failure and hazard analyses
 - Verification of contracted design

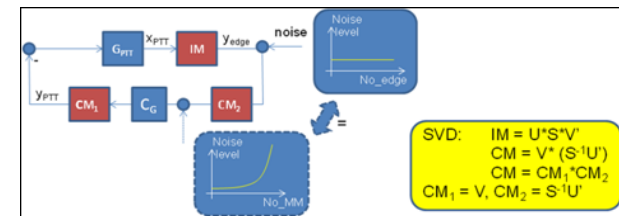
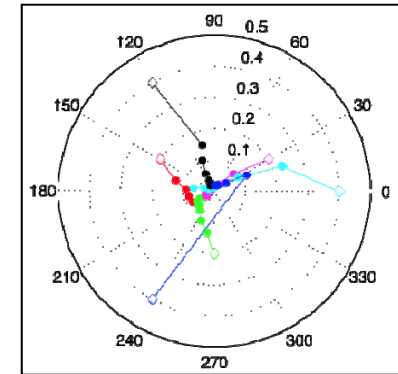



MBSE Telescope Modeling Challenge Team



Artifacts, Artifacts, Artifacts

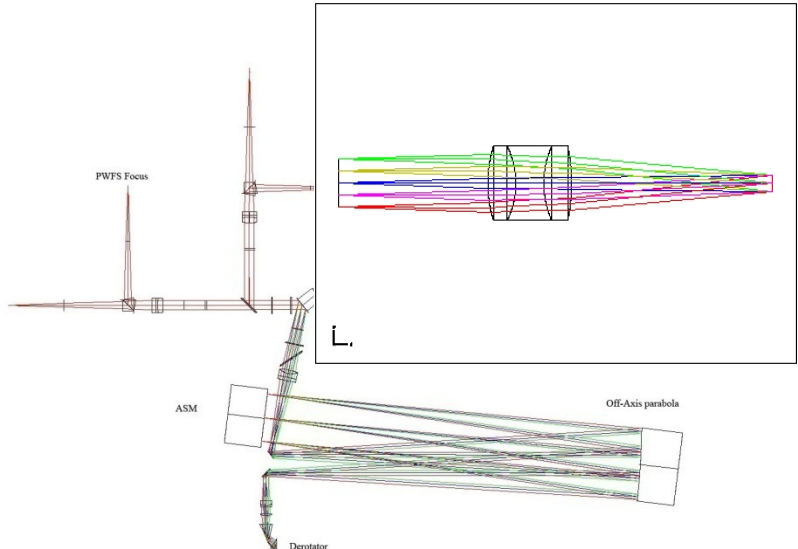
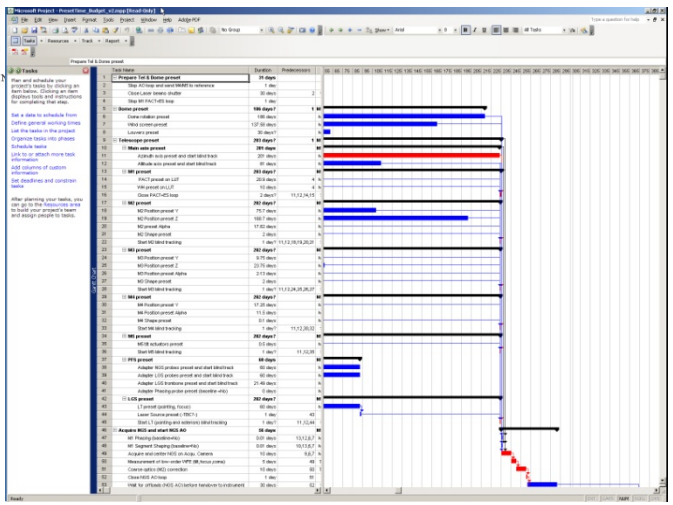



Activity	Fixed time (incl. settling) [sec]	Acceleration [Unit/sec ²]	slew rate [Unit/sec]	Unit	Scale factor: Unit / deg_sky [unit/deg]	Time to slew Az [sec]	Time to slew Alt [sec]	Max time (Az, Alt) [sec]
38 M4 Position preset Alpha	1	4	10	arcsec hexap.	1.143	11.5	11.5	
39 M4 Shape preset	0.1					0.1	0.1	
40 Start M4 blind tracking	1					1.0	1.0	
41 M5 preset								
42 M5 tilt actuators preset	0.5					0.5	0.5	
43 Start M5 blind tracking	1					1.0	1.0	
44 PFS preset								
45 Adapter NGS probes preset and start blind track	0.5	1	6	deg adaptor	1.000	60.0	18.2	60.0
46 Adapter LGS probes preset and start blind track	0.5	1	6	deg adaptor	1.000	60.0	18.2	60.0
47 Adapter LGS trombone preset and start blind track	1	1	10	km_sky/sec	1.500	21.5	21.5	
48 Adapter Phasing probe preset (baseline-No)	0					0.0	0.0	
49 LGS preset								
50 LT preset (pointing, focus)	60					60.0	60.0	60.0
51 Laser Source preset (-TBC7-)	1					1.0	1.0	1.0
52 Start LT (pointing and asterism) blind tracking	1					1.0	1.0	1.0
53 Acquire NGS and start NGS AO								
54 M1 Phasing (baseline-No)	0.01					0.0	0.0	0.0
55 M1 Segment Shaping (baseline-No)	0.01					0.0	0.0	0.0
56 Acquire and center NGS on Acqui. Camera	10					10.0	10.0	10.0
57 Measurement of low-order WFE (tilt, focus, coma)	5					5.0	5.0	5.0
58 Coarse optics (M2) correction	10					10.0	10.0	10.0
59 Close NGS AO loop	1					1.0	1.0	1.0
60 Wait for offloads (NGS AO) before handover to instrument	30					30.0	30.0	30.0
61 Acquire LGS and start LGS AO								
62 Open LT shutter for propagation on sky	30					30.0	30.0	30.0
63 Acquire and center LGS	5					5.0	5.0	5.0
64 LGS NA profile & focus measurement	47					47.0	47.0	47.0



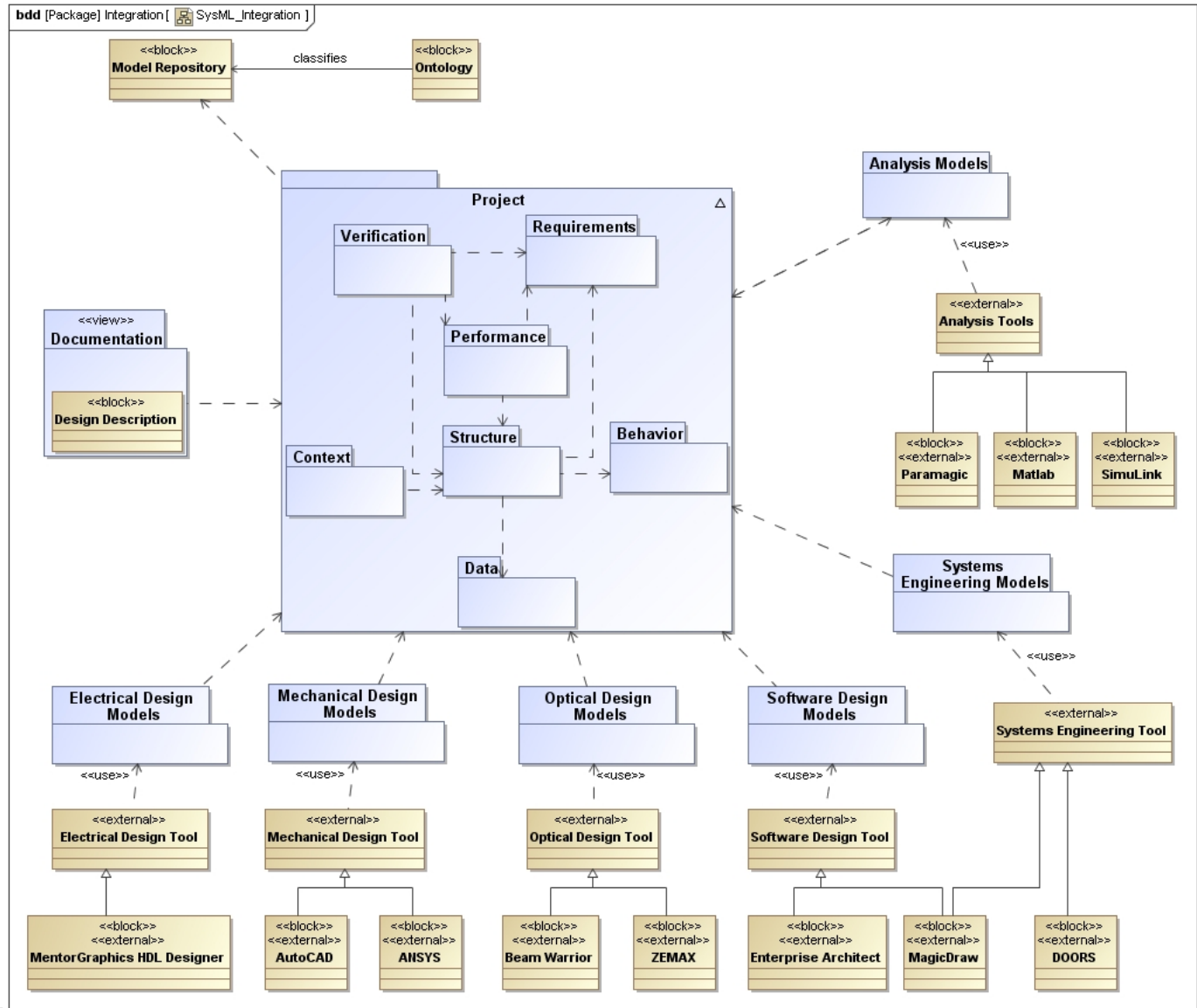

System Model





Modeling

- Integration of different disciplines at system level
- Integration of different discipline specific models and exchange information

- Consistent terminology
- Consistent figures across technical disciplines
- Consistent requirements, analysis, design, integration, and verification
- Compatibility of functional and physical interfaces

- A large part of the above can be enforced, supported, and checked with a Model, using
 - Ontologies
 - Methodology
 - System Modeling Language
 - Modeling recipes, best practices, and patterns
 - Tools

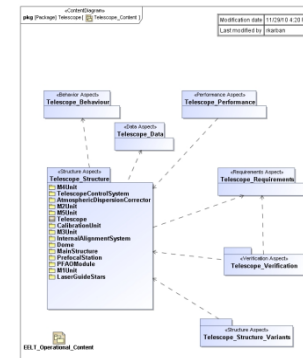



E-ELT Control System

- Includes all hardware, software and communication infrastructure required to control the System
- Provides access to the opto-mechanical components.
- Manages and coordinates system resources (subsystems, sensors, actuators, etc...)
- Performs fault detection and recovery
- The performance and functional control requirements of the entire system are assigned to the TCS.
- Interaction of Control Engineering, Software Engineering and Electrical Engineering

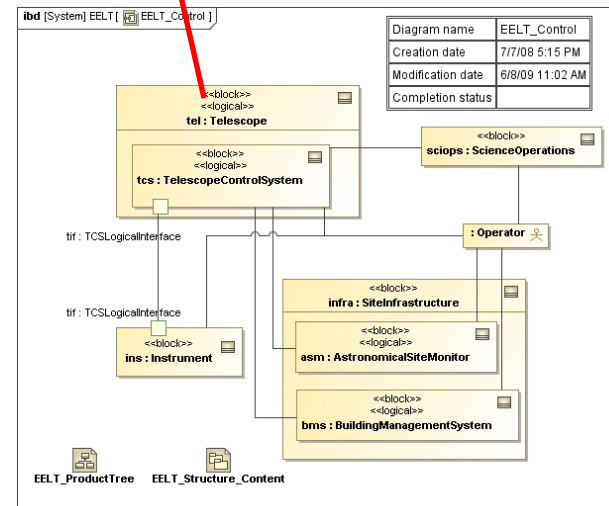
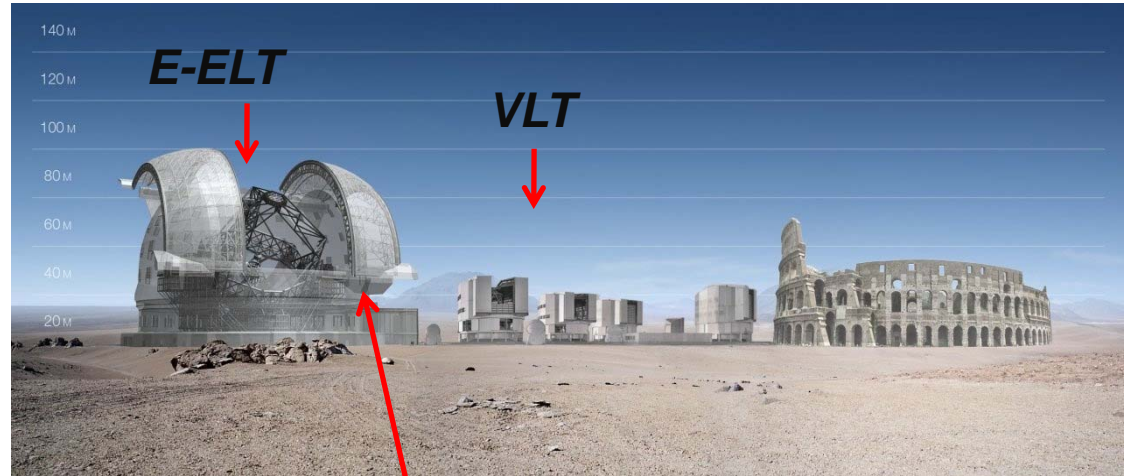



VLT Wavefront control

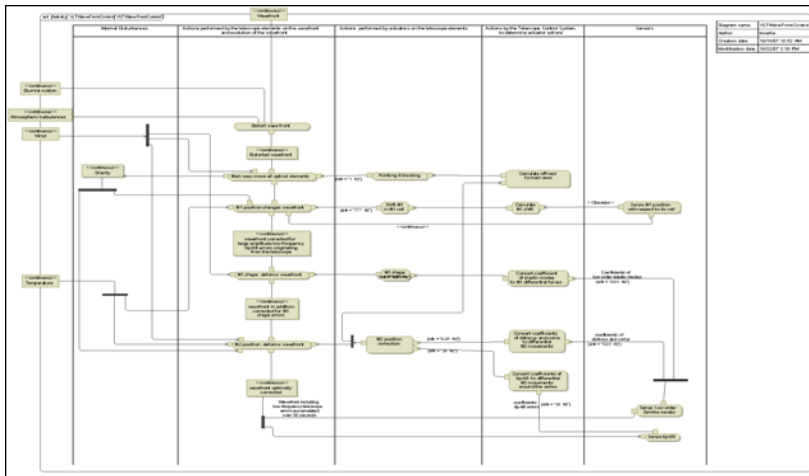

- 10000 tons of steel and glass
- 20000 actuators, 1000 mirrors
- 50000 I/O points, 700Gflops/s, 17Gbyte/s
- Many distributed control loops
- Use MBSE/SysML to model the control system since 2008

E-ELT Wavefront control

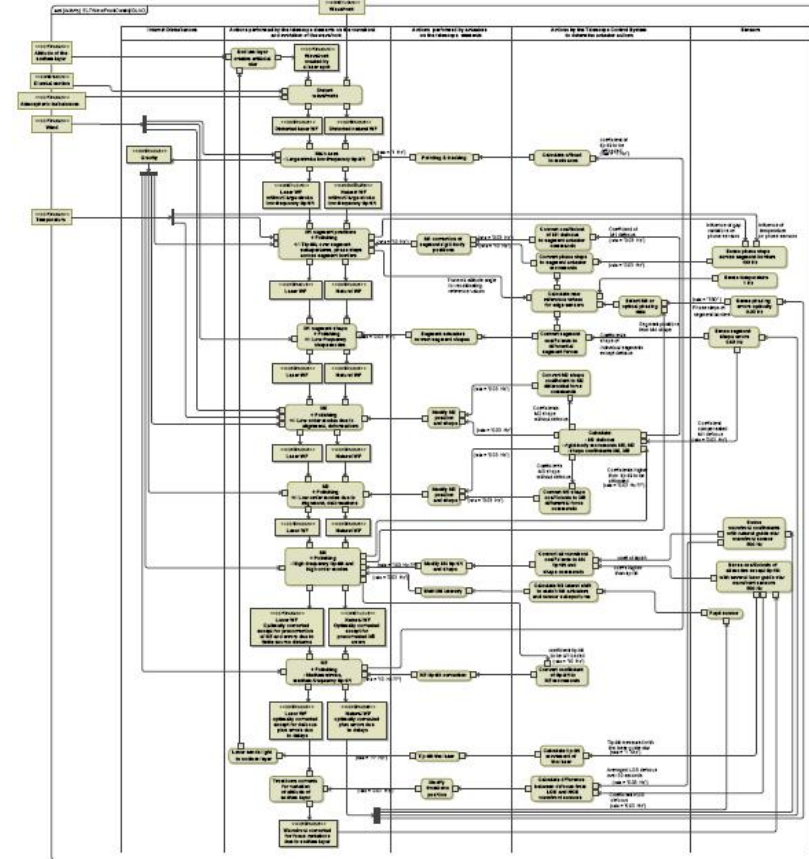



Challenges for the E-ELT CS

- Technical
 - Number of control points
 - Number of interfaces
 - Large data volume
 - Multitude of interacting control loops
 - Software intensive distributed control strategy
- Programmatic
 - Overall function and performance of the telescope is allocated to the control system
 - Long lag between contract set-up and development
 - Integration of heterogeneous distributed components

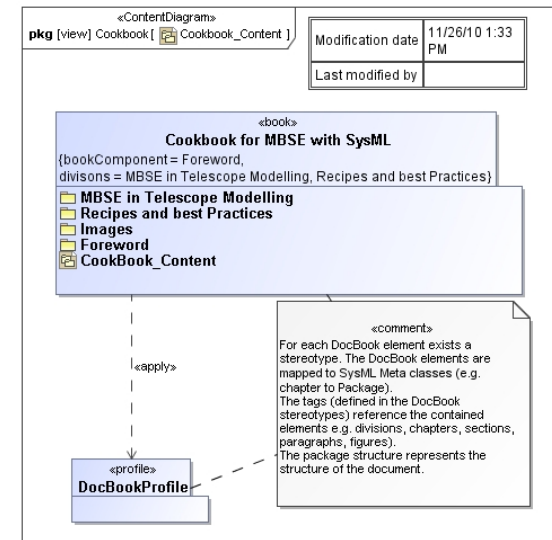



Why a system model for the E-ELT TCS?

- Define infrastructure (e.g. network)
- Derive power budget and cost estimate from equipment catalogue
- Enforce common standards through catalogue and design guidelines
- Define requirements for subsystems (e.g. data rates, data volume, latency)
- Consistent information model of TCS properties to manage its size
- Provide a design which satisfies telescope functions (e.g. wave front control strategies)
- Consistent design achieved through common system model
- Generate Documentation, Software, System Configuration, and Deployment

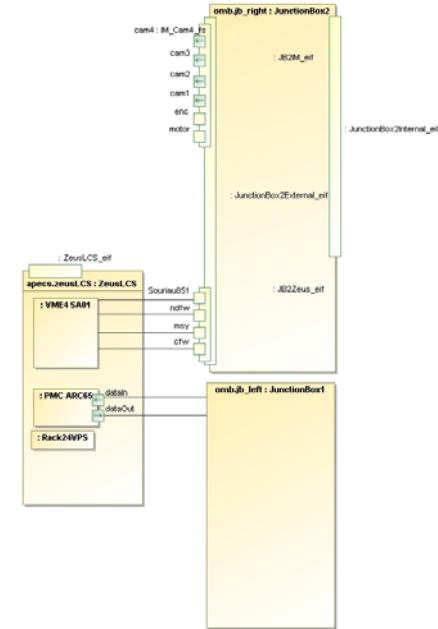



Break Out session topic

- MBSE Cookbook for SysML
 - Cookbook content
 - Experiences and strategies in setting up patterns, guidelines, and recipes
 - Educational aspects
 - Disseminating MBSE in an organization
 - Setting scope of modeling
 - Dynamic MBSE knowledge management in organization
- Model Based Document Generation

- How many of you would be interested?



Summary

- Challenge team activities concentrated in the past years on
 - Demonstrating usability of SysML in large, non-trivial applications
 - Compiling modeling pattern, guidelines, and practices
 - Providing a large amount of real-world examples
 - Providing feed-back to vendors and standardization bodies
- SysML as a language is mature enough to be used
 - Sufficient material is available to answer most modeling questions
- SysML and MBSE concepts are being applied to new projects
 - SysML, OOSEM, and State Analysis are applied within major ESO projects.
- Future Challenges are mainly in the areas of
 - Applying MBSE Methods with SysML
 - Model Execution
 - Usability issues for large scale models
 - Model Evolution
 - Integration with engineering disciplines (tool and standard wise)



Live demo of the APE, E-ELT, and VLT model

- Please standby - setting up the system...

